

A-A

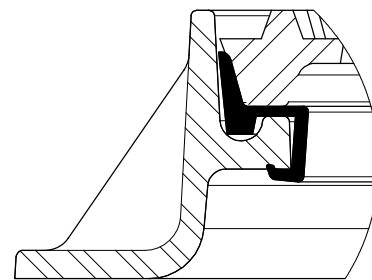
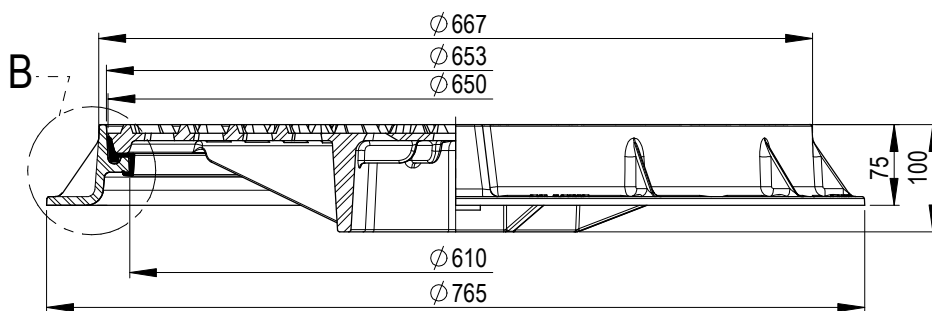

Pormenor - B

NOTA:
Apoio Elástico com aba lateral
em PVC flexível ou EPDM (Opção).

C

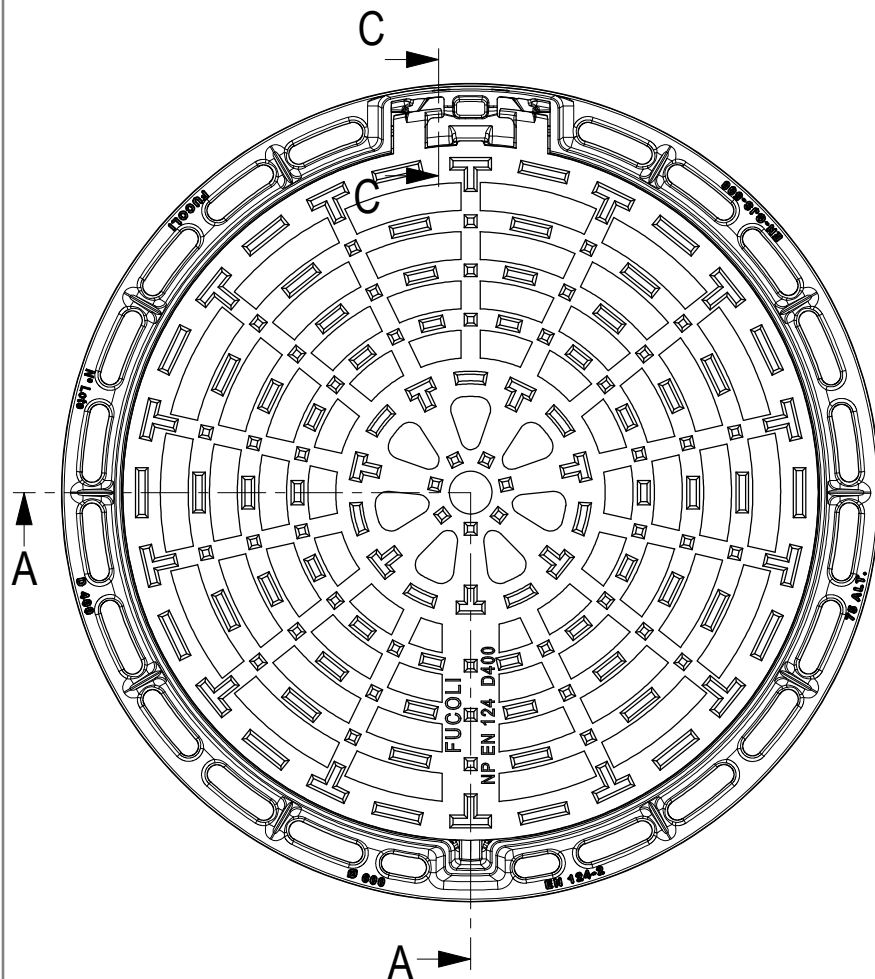

C-C

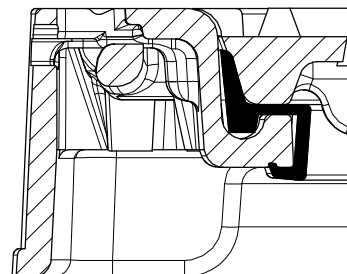

A

A

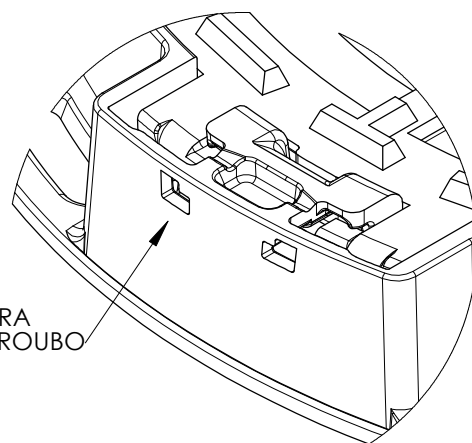

PREPARADA PARA
GANCHO ANTI-ROUBO

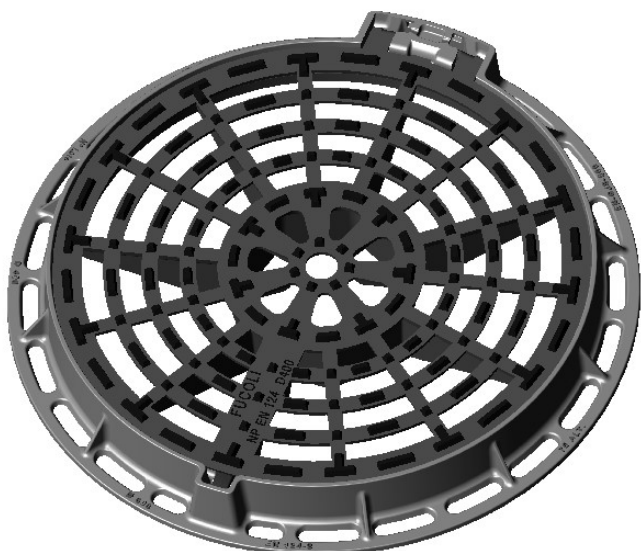

DESIGNAÇÃO
**GRELHA + ARO RED. 60 D400 N F EIXO DOB.
PREPARADA P/ A-R**



COMPONENTE		PESO (Kg)	CARACTERÍSTICAS		DESENHO Nº	
GRELHA	[203.06.276]	30,00			203.03.059	
ARO	[204.12.067]	17,50	COTA DE PASSAGEM	610 mm		
APOIO ELÁSTICO	[MA4331900]	0,65	SUP. APOIO DO ARO	7,17 N/mm ²	TOLER.	ISO 8062-3 DCTG9
FECHO	[204.05.968]	0,40	ÁREA DE PASSAGEM DA ÁGUA NA GRELHA	35,16 % 116694 mm ²	REV. Nº	DATA
Os pesos apresentados podem ter uma variação e são dados a nível indicativo sem valor contratual.					0	06/09/2019