

FLANGED SOFT SEALING GATE VALVE S15 3000

with AUMA electric actuator

DN 40 - 300 PN25

01.204A



Product description

- Flanged soft sealing gate valve series 3000 with AUMA electric actuator for drinking water and neutral liquids
- Service temperature from 0°C (excluding frost) to 70°C

Standards

- Designed according to EN 1074 parte 1 & 2 and EN 1171
- Flange drilling to EN 1092-2 PN25
- Face-to-face according to EN 558 serie 15
- ISO top flange according to ISO 5210
- Auma Norm multi-turn electric actuators with enclosure IP68 according to EN 60529

Tests

All valves are individually hydrostatically tested according to EN 1074-1/2 and EN 12266:

- Seal 1.1 x PN (in bar); Body: 1.5 x PN (in bar)

Corrosion protection

- Epoxy powder coating RAL 5005
- Applied internal and external with a minimum coating thickness of 250 µm
- Potable water approved epoxy coating, fusion bonded according to DIN 3476-1, EN 14901-1 and GSK approved

Approvals

- ACS Potability Certificate 21 ACC NY 005
- GSK Epoxy Coating Certificate GSK-ID:1247 (RAL-GZ 662)

Features

- Isolation valve approved for drinking water
- Full bore
- The valves from DN 250 to DN 300 are equipped with an axial bearing to ensure reduced operating torque
- Stainless steel stem with rolled threads produced by cold rolling process, which keeps the steel structure and increase its mechanical resistance
- Stem sealing system with 4 O-rings in EPDM
- O-ring stem sealing exchangeable under pressure
- Wedge fully vulcanized with drinking water approved EPDM
- Wedge with brass nut fixed in the wedge core preventing vibration and ensure a long life span
- Wedge and body designed with "monorail" system
- Round EPDM bonnet gasket fixed in a recess, surrounding the bolts, ensuring a perfect seal
- Body/bonnet bolts in stainless steel A2 encased and sealed ensuring full corrosion protection
- Auma Norm electric actuator multi-turn SA with three-phase AC motors (3PH - 400V - 50Hz - IP68)
- On request possibility of stem in stainless steel AISI 316L, NBR sealings, wedge nut in different brass alloys, actuator Auma Norm single phase, Auma Matic, Aumatic or others.



Fucoli-Somepal
FUNDICAO DE FERRO, S.A.

Visit our website at www.fucoli-somepal.pt

Head office: Estrada de Coselhas, 3000-125 Coimbra – Portugal | Tel.: (+351) 239 490100

Branch office: Rua de Aveiro 50, 3050-420 Pampilhosa – Portugal | Tel.: (+351) 239 490100 | comercial@fucoli-somepal.pt

FLANGED SOFT SEALING GATE VALVE S15 3000

with AUMA electric actuator

DN 40 - 300 PN25

01.204A

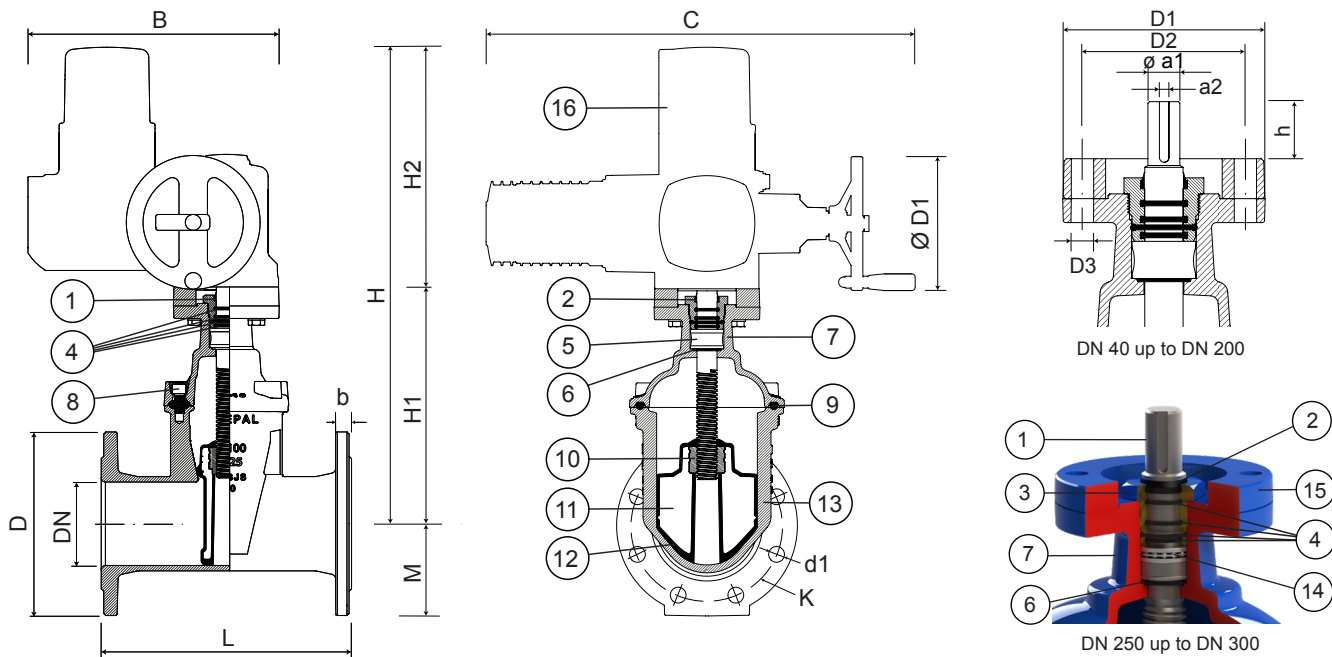

Component list

pos	components	material	standard
1	Stem	Stainless steel AISI 420	EN 10088-1
2	Clearing joint	Elastomer	-
3a	Gland	Brass DZR CW626N	EN 12164
3b	Gland	Ductile iron EN-GJS-500-7	EN 1563
4	O-rings	Elastomer EPDM	EN 681-1
5	Stem washer	Brass DZR CW602N	EN 12164
6	O-rings	Elastomer EPDM	EN 681-1
7	Bonnet	Ductile iron EN-GJS-500-7	EN 1563
8	Bolts	Stainless steel A2	EN 10088-1

pos	components	material	standard
9	Bonnet gasket	Elastomer EPDM	EN 681-1
10	Wedge nut	Brass DZR CW626N	EN 12164
11	Wedge	Ductile iron EN-GJS-500-7	EN 1563
12	Wedge covering	Elastomer EPDM	EN 681-1
13	Body	Ductile iron EN-GJS-500-7	EN 1563
14	Bearing	Steel	ISO 20516
15	Mounting flange	Ductile iron EN-GJS-500-7	EN 1563
16	AUMA electric actuator	-	-

Reference and dimensions

DN	PN	code	D mm	L mm	H mm	H1 mm	M mm	K mm	n° x d1 mm	b mm	ISO 5210 flange	AUMA actuator	B mm	C mm	Ø D1 mm	H2 mm	RPM actuator	closed time s.	Kg aprox.
40	25	10726700A	150	240	496	208	75	110	4 x 19	19	F10	SA 07.6	300	514	160	288	45	17	65
50	25	10726710A	165	250	496	208	83	125	4 x 19	19	F10	SA 07.6	300	514	160	288	45	17	75
60	25	10726720A	175	270	505	217	88	135	4 x 19	19	F10	SA 07.6	300	514	160	288	45	18	85
65	25	10726730A	185	270	505	217	93	145	4 x 19	19	F10	SA 07.6	300	514	160	288	45	18	90
80	25	10726740A	200	280	545	257	100	160	8 x 19	19	F10	SA 07.6	300	514	160	288	45	22	105
100	25	10726750A	235	300	576	286	118	180	8 x 19	19	F10	SA 10.2	313	537	200	290	45	27	128
125	25	10726760A	270	325	613	323	135	210	8 x 19	19	F10	SA 10.2	313	537	200	290	45	34	153
150	25	10726770A	300	350	700	384	150	240	8 x 23	20	F14	SA 14.2	377	725	315	316	45	40	209
200	25	10726780A	360	400	775	459	180	295	8 x 23	22	F14	SA 14.2	377	725	315	316	45	45	259
250	25	10726790A	425	500	931	615	213	350	12 x 23	24.5	F14	SA 14.2	377	725	315	316	22	114	309
300	25	10726800A	485	500	936	620	243	400	12 x 23	27.5	F14	SA 14.6	377	728	400	316	22	137	363

Electric actuator with RPMs other than those mentioned, on request.

For more information on the electric actuator consult the manufacturer's technical documentation.



Fucoli-Somepal
FUNDAÇÃO DE FERRO, S. R.

Visit our website at www.fucoli-somepal.pt

Head office: Estrada de Coselhas, 3000-125 Coimbra – Portugal | Tel.: (+351) 239 490100

Branch office: Rua de Aveiro 50, 3050-420 Pampilhosa – Portugal | Tel.: (+351) 239 490100 | comercial@fucoli-somepal.pt



100% MADE IN EUROPE