

FLANGED SOFT SEALING GATE VALVE S15 3000

with pneumatic cylinder

DN 50 - 300 PN10/16

01.205



Product description

- Flanged soft sealing gate valve series 3000 with pneumatic cylinder actuator for drinking water and neutral liquids
- Service temperature from 0°C (excluding frost) to 70°C

Standards

- Designed according to EN 1074 part 1 & 2 and EN 1171
- Flange drilling to EN 1092-2 PN10/16
- Face-to-face according to EN 558 series 15

Tests

All valves are individually hydrostatically tested according to EN 1074-1/2 and EN 12266:

- Seal 1.1 x PN (in bar); Body: 1.5 x PN (in bar)

Corrosion protection

- Epoxy powder coating RAL 5005
- Applied internal and external with a minimum coating thickness of 250 µm
- Potable water approved epoxy coating, fusion bonded according to DIN 3476-1, EN 14901 and GSK approved

Approvals

- ACS Potability Certificate 15 ACC NY 005
- GSK Epoxy Coating Certificate GSK-ID:1247 (RAL-GZ 662)

Features

- Isolation valve for drinking water
- Full bore
- Shaft sealing system with 3 O-rings in EPDM
- Wedge fully vulcanized with drinking water approved EPDM
- Top of the wedge conceived with “soft stop” system, which acts as an end stop for the fully open valve
- Wedge with brass nut fixed in the wedge core preventing vibration and ensure a long life span
- Wedge and body designed with “monorail” system
- Round EPDM bonnet gasket fixed in a recess, surrounding the bolts, ensuring a perfect seal
- Body/bonnet bolts in stainless steel A2 encased and sealed ensuring full corrosion protection
- Double acting pneumatic actuator with position sensing for open/close operation approved by ATEX
- On request possibility of stem in stainless steel AISI 316L, NBR sealings and wedge nut in different brass grades.



Fucoli Somepal
FUNDAÇÃO DE FERRO, S. A.

Visit our website at www.fucoli-somepal.pt

Head office: Estrada de Coselhas, 3000-125 Coimbra – Portugal | Tel.: (+351) 239 490100 | Fax: (+351) 239 490198

Branch office: Rua de Aveiro 50, 3050-420 Pampilhosa – Portugal | Tel.: (+351) 239 490100 | Fax: (+351) 231 949292 | comercial@fucoli-somepal.pt

FLANGED SOFT SEALING GATE VALVE S15 3000

with pneumatic cylinder

DN 50 - 300 PN10/16

01.205

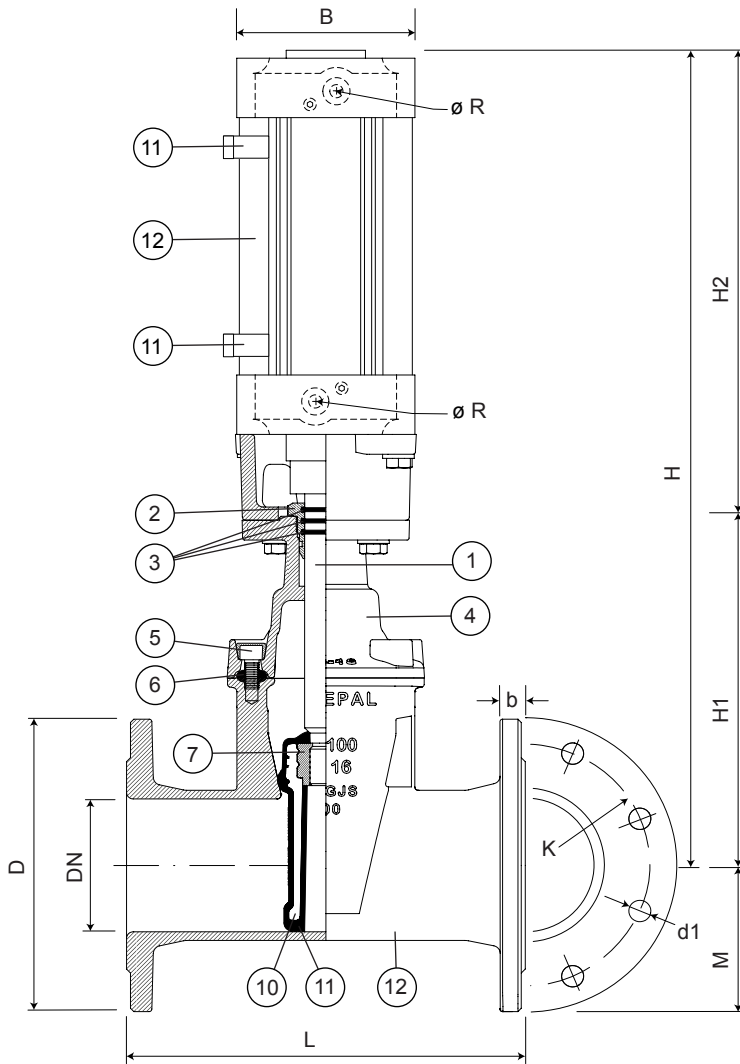

Component list

pos.	components	material	standard
1	Shaft	Stainless steel AISI 420	EN 10088 - 1
2	Stem washer	Brass CW614N	EN 12164
3	O-rings	Elastomer EPDM	EN 681 - 1
4	Bonnet	Ductile iron EN-GJS-500-7	EN 1563
5	Bolts	Stainless steel A2	EN 10088 - 1
6	Bonnet gasket	Elastomer EPDM	EN 681 - 1
7	Wedge nut	Brass CW602N	EN 12164
8	Wedge	Ductile iron EN-GJS-500-7	EN 1563
9	Wedge covering	Elastomer EPDM	EN 681 - 1
10	Body	Ductile iron EN-GJS-500-7	EN 1563
11	Open-close limit switching (option)	-	-
12	Pneumatic cylinder	Aluminium and stainless steel	-

Reference and dimensions

DN	PN	code	D	L	H	M	H1	H2	K	n° x d1	b	B	ø R	Kg approx.
			mm	mm	mm	mm	mm	mm	mm	mm	mm	mm	mm	
40	10/16	10727200	150	240	283	75	208	75	110	4 x 19	19	100	G 1/2"	16
50	10/16	10727205	165	250	283	83	208	75	125	4 x 19	19	100	G 1/2"	18
60	10/16	10727210	175	270	307	88	217	90	135	4 x 19	19	100	G 1/2"	20
65	10/16	10727215	185	270	307	93	217	90	145	4 x 19	19	100	G 1/2"	20
80	10/16	10727220	200	280	362	100	257	105	160	8 x 19	19	125	G 3/4"	25
100	10/16	10727225	220	300	411	110	286	125	180	8 x 19	19	125	G 3/4"	33
125	10/16	10727230	250	325	473	125	323	150	210	8 x 19	19	160	G 3/4"	46
150	10/16	10727235	285	350	559	143	384	175	240	8 x 23	19	160	G 3/4"	60
200	10	10727240	340	400	684	170	459	225	295	8 x 23	20	200	G 3/4"	86
200	16	10727242	340	400	684	170	459	225	295	12 x 23	20	200	G 3/4"	86
250	10	10727245	400	450	820	200	545	275	350	12 x 23	22	200	G 1"	138
250	16	10727250	400	450	820	200	545	275	355	12 x 28	22	200	G 1"	138
300	10	10727255	455	500	945	228	620	325	400	12 x 23	24.5	200	G 1"	200
300	16	10727260	455	500	945	228	620	325	410	12 x 28	24.5	200	G 1"	200



Fucoli Somepal
FUNDAÇÃO DE FERRO, S.A.

Visit our website at www.fucoli-somepal.pt

Head office: Estrada de Coselhas, 3000-125 Coimbra – Portugal | Tel.: (+351) 239 490100 | Fax: (+351) 239 490198

Branch office: Rua de Aveiro 50, 3050-420 Pampilhosa – Portugal | Tel.: (+351) 239 490100 | Fax: (+351) 231 949292 | comercial@fucoli-somepal.pt



100% MADE IN EUROPE