

DOUBLE MOVABLE FLANGED PIPE

DN 40 - 500 PN10/16

11.2901



Product description

- Ductile iron pipe for waste water

Standards

- Designed according to EN 598
- Flange drilling to EN 1092-2 (ISO 7005-2) PN 10/16

Tests

- All pipes are individually hydrostatically tested according to EN 598

Corrosion protection

- Epoxy powder coating RAL 3011
- Applied internal and external with a minimum coating thickness of 250 µm
- Fusion bonded epoxy coating according EN 14901-1, and GSK (RAL-GZ662) guidelines

Features

- Pipe for waste water
- Body and flange in ductile cast iron (EN-GJS-500-7)
- Flanged fitting connecting any flanged component
- Puddle flange in the center of movable flanged pipe
- Ductile cast iron pipe available in 3 models:
 - A. Double movable flanged pipe L = 250 mm
 - B. Double movable flanged pipe L = 500 mm
 - C. Double movable flanged pipe with puddle flange L = 500 mm
- The flanged fittings for sewerage applications from Fucoli-Somepal have CE mark in accordance with standard EN 598 annex ZA.

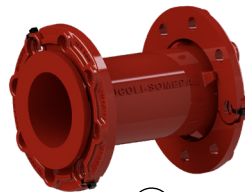

A



B

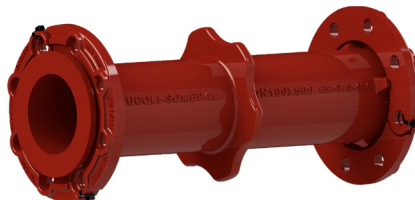

C



Fucoli-Somepal
FUNDAÇÃO DE FERRO, S.A.

Visit our website at www.fucoli-somepal.pt

Head office: Estrada de Coselhas, 3000-125 Coimbra – Portugal | Tel.: (+351) 239 490100 | Fax: (+351) 239 490198

Branch office: Rua de Aveiro 50, 3050-420 Pampilhosa – Portugal | Tel.: (+351) 239 490100 | Fax: (+351) 231 949292 | comercial@fucoli-somepal.pt

DOUBLE MOVABLE FLANGED PIPE DN 40 - 500 PN10/16

11.2901

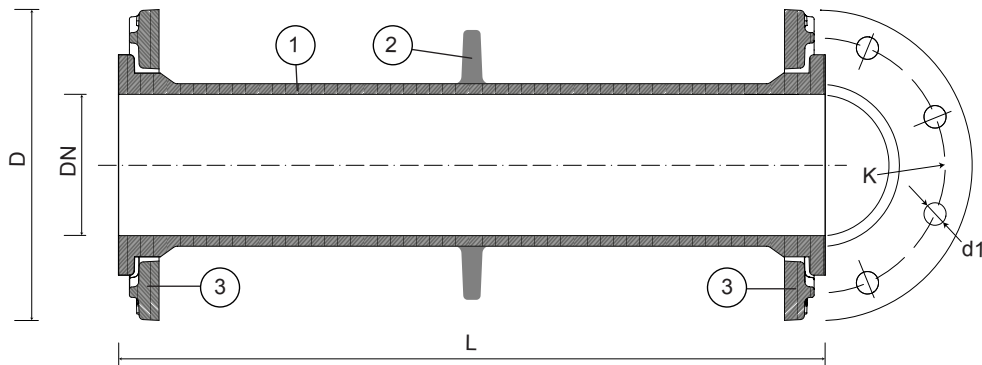

Component list

pos.	components	material	standard
1	Pipe	Ductile iron EN-GJS-500-7	EN 1563
2*	Puddle flanged	Ductile iron EN-GJS-500-7	EN 1563
3	Flange	Ductile iron EN-GJS-500-7	EN 1563

* Only available in the model double movable flanged pipe with puddle flange

Reference and dimensions

Common on all models

Hole \varnothing / \varnothing and n° of holes

DN	PN	D mm	K mm	n° x d1 mm	DN	PN	D mm	K mm	n° x d1 mm	DN	PN	D mm	K mm	n° x d1 mm
40	10/16	150	110	4 x 19	125	10/16	250	210	8 x 19	300	16	455	410	12 x 28
50	10/16	165	125	4 x 19	150	10/16	285	240	8 x 23	400	10	565	515	16 x 28
60	10/16	175	135	4 x 19	200	10/16	340	295	8 - 12 x 23	400	16	580	525	16 x 31
65	10/16	185	145	4 x 19	250	10	400	350	12 x 23	500	10	670	620	20 x 28
80	10/16	200	160	8 x 19	250	16	400	355	12 x 28	500	16	715	650	20 x 34
100	10/16	220	180	8 x 19	300	10	455	400	12 x 23					

Models

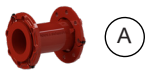

(A)

DN	PN	code	L mm	Kg approx.
40	10/16	40248010	250	6
50	10/16	40248020	250	7
60	10/16	40248030	250	7
65	10/16	40248040	250	8
80	10/16	40248050	250	9
100	10/16	40248060	250	11
125	10/16	40248070	250	14
150	10/16	40248080	250	16
200	10/16	40248090	250	23
250	10	40248100	250	36
250	16	40248095	250	-
300	10	40248110	250	46
300	16	40248115	250	48



(B)

DN	PN	code	L mm	Kg approx.
40	10/16	40250010	500	8
50	10/16	40250020	500	9
60	10/16	40250030	500	10
65	10/16	40250040	500	11
80	10/16	40250050	500	13
100	10/16	40250060	500	15
125	10/16	40250070	500	17
150	10/16	40250080	500	23
200	10/16	40250090	500	35
250	10	40250100	500	45
250	16	40250105	500	46
300	10	40250110	500	60
300	16	40250115	500	61
400	10	40250120	500	94
400	16	40250125	500	99
500	10	40250130	500	124
500	16	40250135	500	145



(C)

DN	PN	code	L mm	Kg approx.
40	10/16	40252010	500	8
50	10/16	40252020	500	10
60	10/16	40252030	500	11
65	10/16	40252040	500	12
80	10/16	40252050	500	14
100	10/16	40252060	500	17
125	10/16	40252070	500	21
150	10/16	40252080	500	26
200	10/16	40252090	500	38
250	10	40252100	500	48
250	16	40252105	500	50
300	10	40252110	500	62
300	16	40252115	500	65
400	10	40252120	500	100
400	16	40252125	500	105
500	10	40252130	500	130
500	16	40252135	500	150



Fucoli-Somepal
FUNDAÇÃO DE FERRO, S. R. L.

Visit our website at www.fucoli-somepal.pt

Head office: Estrada de Coselhas, 3000-125 Coimbra – Portugal | Tel.: (+351) 239 490100 | Fax: (+351) 239 490198 comercial.sede@fucoli-somepal.pt

Branch office: Rua de Aveiro 50, 3050-420 Pampilhosa – Portugal | Tel.: (+351) 239 490100 | Fax: (+351) 231 949292 comercial.filial@fucoli-somepal.pt

