

FLANGED SOFT SEALING GATE VALVE S14 NEXUS DN 50 - 300 PN10/16

11.110



Product description

- Flanged soft sealing gate valve S14 series NEXUS for waste water
- Service temperature from 0°C (excluding frost) to 70°C

Standards

- Designed according to EN 1074 part 1 & 2 and EN 1171
- Flange drilling to EN 1092-2 PN10/16
- Face-to-face according to EN 558 series 14

Tests

All valves are individually hydrostatically tested according to EN 1074-1/2 and EN 12266:

- Seal 1.1 x PN (in bar); Body: 1.5 x PN (in bar). Operation torque test

Corrosion protection

- Epoxy powder coating RAL 3011
- Applied internal and external with a minimum coating thickness of 250 µm
- Fusion bonded epoxy coating according to DIN 3476-1, EN 14901 and GSK (RAL-GZ662) guidelines

Features

- Isolation valve approved for waste water
- Full bore
- Brass stem washer provides stress fixation and low operating torque
- Stainless steel stem with rolled threads produced by cold rolling process, which keeps the steel structure and increase its mechanical resistance
- Stem with stainless steel wedge stop to serve as backstop when the valve is fully open
- Stem sealing with POM bearing with 4 O-rings and a bottom joint in NBR
- Wedge fully vulcanized with NBR
- Wedge of polyamide coated guide rails avoiding friction and corrosion
- Wedge with brass nut fixed in the wedge core preventing vibration and ensure a long life span
- Round NBR bonnet gasket fixed in a recess, surrounding the bolts, ensuring a perfect seal
- Body/bonnet bolts in stainless steel A2 encased and sealed ensuring full corrosion protection
- Accessories: handwheel [ref.05.100], stem cap [ref. 05.200], extension spindle [ref. 05.300] and surface box [ref. 05.500].



Fucoli Somepal
FUNDAÇÃO DE FERRO, S.A.

Visit our website at www.fucoli-somepal.pt

Head office: Estrada de Coselhas, 3000-125 Coimbra – Portugal | Tel.: (+351) 239 490100 | Fax: (+351) 239 490198

Branch office: Rua de Aveiro 50, 3050-420 Pampilhosa – Portugal | Tel.: (+351) 239 490100 | Fax: (+351) 231 949292 | comercial@fucoli-somepal.pt



FLANGED SOFT SEALING GATE VALVE S14 3000

DN 50 - 300 PN10/16

11.110

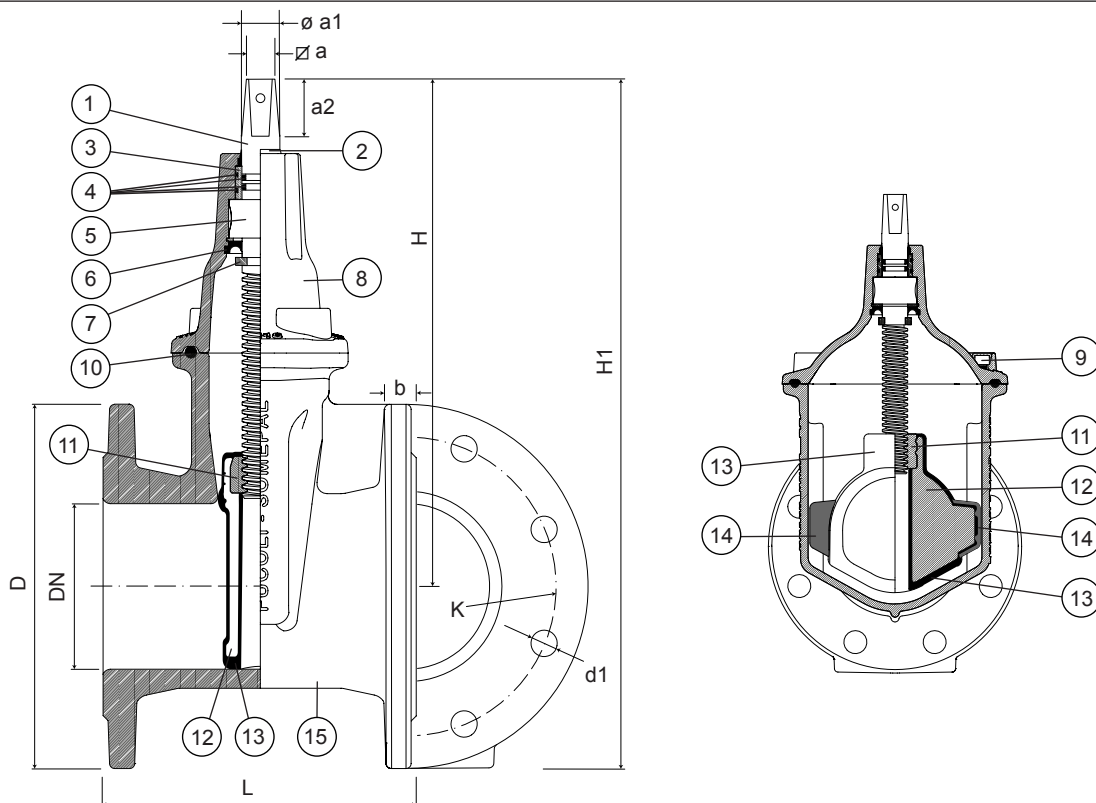

Component list

pos.	components	material	standard
1	Stem	Stainless steel AISI 316L	EN 10088 - 1
2	Clearing joint	Elastomer	-
3	Bearing	POM	-
4	O-rings	Elastomer NBR	EN 681 - 1
5	Stem washer	Brass	EN 12164
6	Joint	Elastomer NBR	EN 681 - 1
7	Wedge stop	Stainless steel AISI 316L	EN 10088 - 1
8	Bonnet	Ductile iron EN-GJS-500-7	EN 1563

pos.	components	material	standard
9	Bolts	Stainless steel A2	EN 10088 - 1
10	Bonnet gasket	Elastomer NBR	EN 681 - 1
11	Wedge nut	Brass	EN 12164
12	Wedge	Ductile iron EN-GJS-500-7	EN 1563
13	Wedge covering	Elastomer NBR	EN 681 - 1
14	Wedge guide	Polyamide	-
15	Body	Ductile iron EN-GJS-500-7	EN 1563

Reference and dimensions

DN	PN	code	D	L	H	H1	K	n° x d1	b	∅ a	∅ a1	a2	turns to open	Kg approx.
			mm	min	mm	mm	mm	mm	mm	mm	mm	mm		
50	10/16	10739010	165	150	214	297	125	4 x 19	19	14.1	18	29	13	10
60*	10/16	10729015FL	185	170	252	345	135	4 x 19	19	17.1	22	34	14	12
65	10/16	10739015	185	170	252	345	145	4 x 19	19	17.1	22	34	14	12
80	10/16	10739020	200	180	277	377	160	8 x 19	19	17.1	22	34	16	14
100	10/16	10739025	220	190	306	416	180	8 x 19	19	19.1	23	38	20	17
125	10/16	10739030	250	200	342	467	210	8 x 19	19	19.1	23	38	25	22
150	10/16	10739035	285	210	400	542	240	8 x 23	19	19.1	26	38	30	31
200	10	10739040	340	230	471	641	295	8 x 23	20	24.1	28	38	40	47
200	16	10739045	340	230	471	641	295	12 x 23	20	24.1	28	38	40	47
250	10	10739050	400	250	601	801	350	12 x 23	22	27.1	32	47	42	72
250	16	10739055	400	250	601	801	355	12 x 28	22	27.1	32	47	42	72
300	10	10739060	455	270	682	910	400	12 x 23	24.5	27.1	32	47	50	98
300	16	10739065	455	270	682	910	410	12 x 28	24.5	27.1	32	47	50	98

* DN65 valve with DN60 flange drilling



Fucoli Somepal
FUNDAÇÃO DE FERRO, S.A.

Visit our website at www.fucoli-somepal.pt

Head office: Estrada de Coselhas, 3000-125 Coimbra – Portugal | Tel.: (+351) 239 490100 | Fax: (+351) 239 490198

Branch office: Rua de Aveiro 50, 3050-420 Pampilhosa – Portugal | Tel.: (+351) 239 490100 | Fax: (+351) 231 949292 | comercial@fucoli-somepal.pt

