

SWING CHECK VALVE SUPRA

metal seated with lever and counterweight

DN 50 - 600 PN10/16

03.107



Product description

- Swing check valve metal seated with lever and counterweight series SUPRA for drinking water and neutral liquids
- Service temperature from 0°C (excluding frost) to 70°C

Standards

- Designed according to EN 1074 part 3
- Flange drilling to EN 1092-2 PN10/16
- Face-to-face according to EN 558 table 2 series 48

Tests

All valves are individually hydrostatically tested according to EN 1074-3:

- Seal 1.1 x PN (in bar); Body: 1.5 x PN (in bar).

Corrosion protection

- Epoxy powder coating RAL 5005
- Applied internal and external with a minimum coating thickness of 250 µm
- Potable water approved epoxy coating, fusion bonded according DIN 3476-1, EN 14901-1 and GSK approved

Approvals

- GSK Epoxy Coating Certificate GSK-ID:1247 (RAL-GZ 662)

Features

- Valve with automatic mechanical closing for installation in pumping systems preventing the return of the flow
- Compact design requires little space for assembly
- The valve should be installed on the horizontal or vertical position, the flow must coincide with the arrow direction engraved on the valve body
- Possibility of installing the lever to the left or right of the valve, making it easy to apply to walls or other obstacles
- Full complete passage without obstacles, avoiding head loss
- Effect of cavitation almost null, due to geometric configuration of the valve
- Easy to maintain, if necessary, components may be replaceable. Disassembly can be accomplished without withdrawing the valve from the pipeline by loosening the screws of the bonnet can remove entire sealing system
- Reliability and stability of the sealing system, designed with double arm support on the shaft and obturator design that allows to fit to the valve body seal
- Valve body supplied as standard with bronze seat
- Obturator in stainless steel AISI 420
- Round EPDM bonnet gasket fixed in a recess, surrounding the bolts, ensuring a perfect seal
- On request possibility to be supplied with obturator in stainless steel AISI 316L, by-pass and plug application to check and clean.



RAL GUTZEICHEN
SCHWEISS KENNZEICHEN
VON ARMATUREN UND FORMSTÜCKEN



100% MADE IN EUROPE



Fucoli-Somepal
FUNDAÇÃO DE FERRO, S.A.

Visit our website at www.fucoli-somepal.pt

Head office: Estrada de Coselhas, 3000-125 Coimbra – Portugal | Tel.: (+351) 239 490100 | Fax: (+351) 239 490198

Branch office: Rua de Aveiro 50, 3050-420 Pampilhosa – Portugal | Tel.: (+351) 239 490100 | Fax: (+351) 231 949292 | comercial@fucoli-somepal.pt

SWING CHECK VALVE SUPRA

metal seated with lever and counterweight

DN 50 - 600 PN10/16

03.107

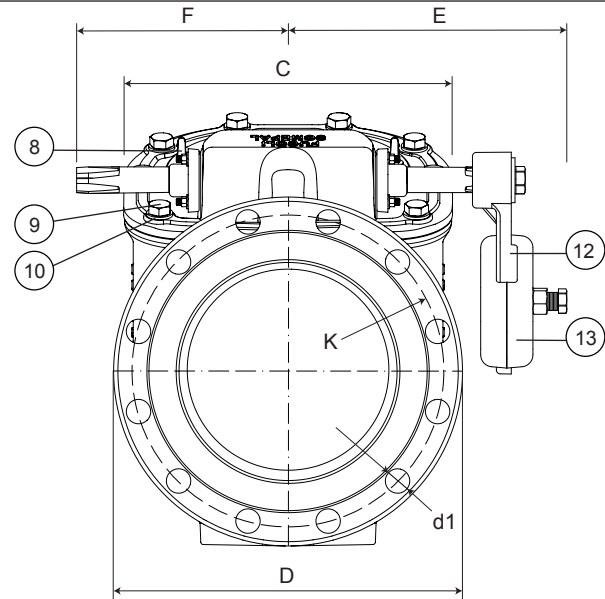
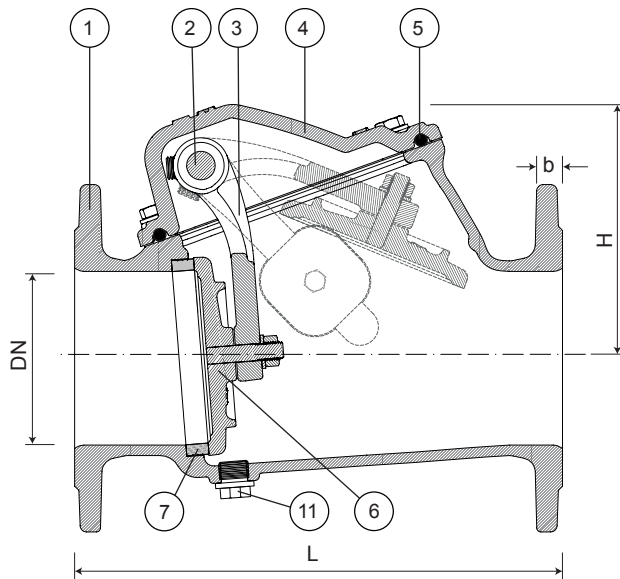

Component list

pos.	components	material	standard
1	Body	Ductile iron EN-GJS-500-7	EN 1563
2	Shaft	Stainless steel AISI 316L	EN 10088 - 1
3	Arm	Ductile iron EN-GJS-500-7	EN 1563
4	Bonnet	Ductile iron EN-GJS-500-7	EN 1563
5	Bonnet gasket	Elastomer EPDM	EN 681 - 1
6	Obturator	Stainless Steel AISI 420	EN 10088 - 1
7	Seat	Bronze CuSn ₇ Zn ₄ Pb ₇	EN 1982

pos.	components	material	standard
8	Lifting eyes (from DN 200)	Stainless steel A2	EN 10088 - 1
9	Bolts	Stainless steel A2	EN 10088 - 1
10	Washers	Stainless steel A2	EN 10088 - 1
11	Plug (option)	Stainless steel A4	EN 10088 - 1
12	Lever	Ductile iron EN-GJS-500-7	EN 1563
13	Counterweight	Ductile iron EN-GJS-500-7	EN 1563

Reference and dimensions

DN	PN	code	D	L	H	C	E	F	K	n° x d1	b	Kg
			mm	mm	mm	mm	mm	mm	mm	mm	mm	approx.
50	10/16	10792010	165	200	108	110	138	104	125	4 x 19	19	11
60	10/16	10792020	175	240	119	123	148	115	135	4 x 19	19	13
65	10/16	10792030	185	240	119	123	148	115	145	4 x 19	19	13
80	10/16	10792040	200	260	137	140	166	122	160	8 x 19	19	16
100	10/16	10792050	220	300	157	168	175	135	180	8 x 19	19	22
125	10/16	10792060	250	350	186	215	205	155	210	8 x 19	19	33
150	10/16	10792070	285	400	210	242	220	170	240	8 x 23	19	46
200	10	10792080	340	500	242	295	250	200	295	8 x 23	20	69
200	16	10792085	340	500	242	295	250	200	295	12 x 23	20	69
250	10	10792090	400	600	296	377	287	232	350	12 x 23	22	98
250	16	10792095	400	600	296	377	287	232	355	12 x 28	22	98
300	10	10792100	455	700	325	427	310	260	400	12 x 23	24.5	138
300	16	10792105	455	700	325	427	310	260	410	12 x 28	24.5	140
350	10	10792110	505	800	400	480	340	280	460	16 x 23	24.5	151
350	16	10792115	520	800	400	480	340	280	470	16 x 28	26.5	158
400	10	10792120	565	900	435	531	387	330	515	16 x 28	24.5	286
400	16	10792125	580	900	435	531	387	330	525	16 x 31	28	291
450	10	10792130	615	1000	460	585	394	337	565	20 x 28	25.5	391
450	16	10792135	640	1000	460	585	394	337	585	20 x 31	30	406
500	10	10792140	670	1100	485	640	422	365	620	20 x 28	26.5	420
500	16	10792145	715	1100	485	640	422	365	650	20 x 34	31.5	445
600	10	10792150	780	1300	585	750	477	420	725	20 x 31	30	620
600	16	10792155	840	1300	585	750	477	420	770	20 x 37	36	670



Fucoli-Somepal
FUNDAÇÃO DE FERRO, S. R. L.

Visit our website at www.fucoli-somepal.pt

Head office: Estrada de Coselhas, 3000-125 Coimbra – Portugal | Tel.: (+351) 239 490100 | Fax: (+351) 239 490198

Branch office: Rua de Aveiro 50, 3050-420 Pampilhosa – Portugal | Tel.: (+351) 239 490100 | Fax: (+351) 231 949292 | comercial@fucoli-somepal.pt



100% MADE IN EUROPE