

## ADAPTOR INTERNAL THREAD/SOCKET FOR PE

10.6200

### Fitting for PE pipe 25 - 63 PN16



#### Product description

- Adaptor with internal thread and one end with tensile resistant socket joint for PE pipes for drinking water and neutral liquids
- Service temperature from 0°C (excluding frost) to 70°C

#### Standards

- Socket for PE pipes PE 80 and PE 100 according EN 12201 and DIN 8074
- Internal parallel BSP thread (Type G) according to ISO 228-1 and ISO 1179-1

#### Corrosion protection

- Epoxy powder coating RAL 5005
- Applied internal and external with a minimum coating thickness of 250 µm
- Potable water approved epoxy coating, fusion bonded according EN 14901 and GSK (RAL-GZ662) guidelines

#### Features

- Fitting for drinking water
- Body in ductile cast iron (EN-GJS-500-7)
- Sockets with EPDM double lip seal ring and POM tension ring ensuring a perfect sealing and PE pipe restraint
- Fitting to assemble PE pipes to a thread connection
- On request possibility of sealing in NBR.



**Fucoli Somepal**  
FUNDAÇÃO DE FERRO, S. A.

Visit our website at [www.fucoli-somepal.pt](http://www.fucoli-somepal.pt)

**Head office:** Estrada de Coselhas, 3000-125 Coimbra – Portugal | Tel.: (+351) 239 490100 | Fax: (+351) 239 490198

**Branch office:** Rua de Aveiro 50, 3050-420 Pampilhosa – Portugal | Tel.: (+351) 239 490100 | Fax: (+351) 231 949292 | [comercial@fucoli-somepal.pt](mailto:comercial@fucoli-somepal.pt)

# ADAPTOR INTERNAL THREAD/SOCKET FOR PE

Fitting for PE pipe  
25 - 63 PN16

10.6200

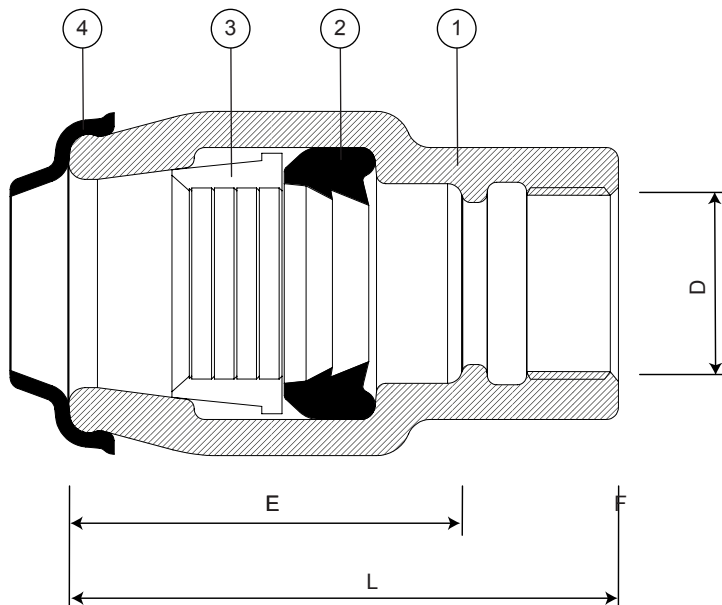

## Component list

| pos. | components     | material                  | standard     |
|------|----------------|---------------------------|--------------|
| 1    | Body           | Ductile iron EN-GJS-500-7 | EN 1563      |
| 2    | Lip seal ring  | Elastomer EPDM            | EN 681 - 1   |
| 3    | Tension ring   | POM                       | EN 10088 - 1 |
| 4    | Protection cap | Elastomer EPDM            | EN 681 - 1   |

## Reference and dimensions

| $\varnothing$<br>ext. PE | D<br>(BSP) | code     | L<br>mm | E<br>mm | F<br>mm | Kg<br>approx. |
|--------------------------|------------|----------|---------|---------|---------|---------------|
| 25                       | G 3/4"     | 10480500 | 80      | 58      | 12      | 1             |
| 32                       | G 1"       | 10480505 | 95      | 68      | 16      | 1             |
| 40                       | G 1 1/4"   | 10480510 | 108     | 77      | 20      | 2             |
| 50                       | G 1 1/2"   | 10480515 | 128     | 96      | 20      | 2             |
| 63                       | G 2"       | 10480520 | 150     | 110     | 25      | 3             |



**Fucoli Somepal**  
FUNDAÇÃO DE FERRO, S.A.

Visit our website at [www.fucoli-somepal.pt](http://www.fucoli-somepal.pt)

Head office: Estrada de Coselhas, 3000-125 Coimbra – Portugal | Tel.: (+351) 239 490100 | Fax: (+351) 239 490198

Branch office: Rua de Aveiro 50, 3050-420 Pampilhosa – Portugal | Tel.: (+351) 239 490100 | Fax: (+351) 231 949292 | [comercial@fucoli-somepal.pt](mailto:comercial@fucoli-somepal.pt)



100% MADE IN EUROPE