



## FIRE PLUG WITH SOFT SEALING GATE VALVE

### Product description

- Fire plug with soft sealing gate valve for drinking water and neutral liquids
- Service temperature from 0°C (excluding frost) to 70°C

### Standards

- Designed according to EN 1074 part 1 & 2 and EN 1171
- Internal and external parallel BSP thread (Type G) according to ISO 228-1 and ISO 1179-1
- Storz outlet according to DIN 14311

### Tests

All valves are individually hydrostatically tested according to EN 1074-1/2 and EN 12266:

- Seal 1.1 x PN (in bar); Body: 1.5 x PN (in bar). Operation torque test

### Corrosion protection

- Epoxy powder coating RAL 5005
- Applied internal and external with a minimum coating thickness of 250 µm
- Potable water approved epoxy coating fusion bonded according to EN 14901 and GSK (RAL-GZ662) guidelines

### Features

- Full bore
- Low operating torque
- Brass stem washer provides stress fixation and low operating torque
- Stainless steel stem with rolled threads produced by cold rolling process, which keeps the steel structure and increase its mechanical resistance
- Stem sealing with POM bearing with 4 O-rings and a bottom joint in EPDM
- Brass wedge fully vulcanized with drinking water approved EPDM
- Round EPDM bonnet gasket fixed in a recess ensuring a perfect seal
- Body/bonnet bolts in stainless steel A2 encased and sealed ensuring full corrosion protection
- Storz 52 outlet that can be equipped with a storz outlet with purgador or with storz inviolable blank cap
- Accessories: handwheel [ref.05.100] and stem cap [ref. 05.200]
- On request possibility of stem in stainless steel AISI 316L or with different water outlets.

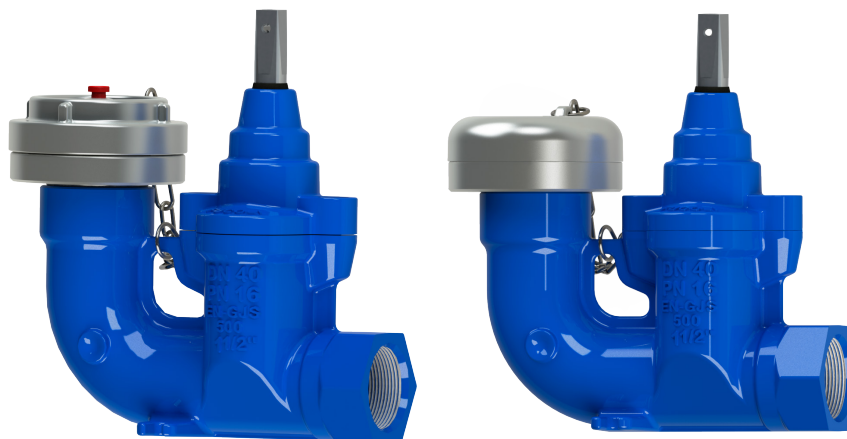

**Fucoli Somepal**  
FUNDAÇÃO DE FERRO, S. A.

Visit our website at [www.fucoli-somepal.pt](http://www.fucoli-somepal.pt)

Head office: Estrada de Coselhas, 3000-125 Coimbra – Portugal | Tel.: (+351) 239 490100 | Fax: (+351) 239 490198

Branch office: Rua de Aveiro 50, 3050-420 Pampilhosa – Portugal | Tel.: (+351) 239 490100 | Fax: (+351) 231 949292 | [comercial@fucoli-somepal.pt](mailto:comercial@fucoli-somepal.pt)



## FIRE PLUG WITH SOFT SEALING GATE VALVE

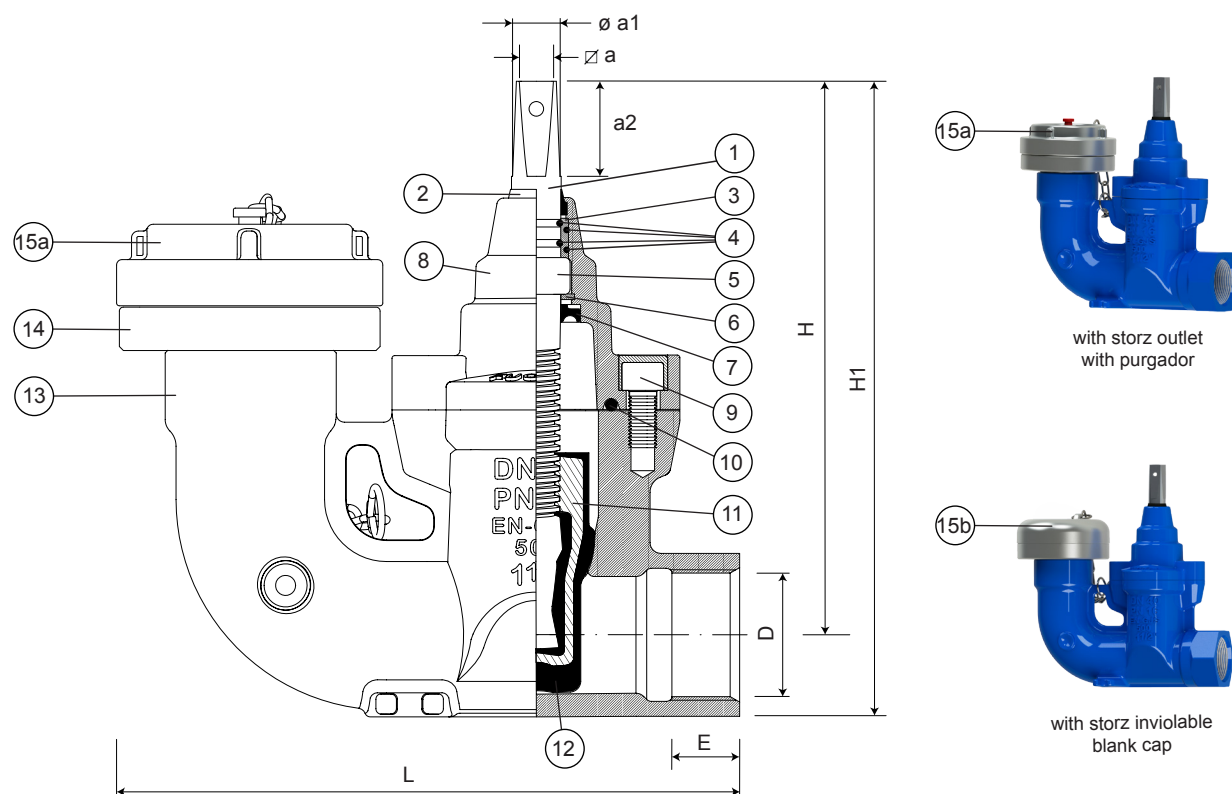

### Component list

pos.	components	material	standard
1	Stem	Stainless steel AISI 420	EN 10088 - 1
2	Clearing joint	Elastomer	
3	Bearing	POM	
4	O-rings	Elastomer EPDM	EN 681 - 1
5	Stem washer	Brass	EN 12164
6	Retaining ring	Stainless steel A2	EN 10088 - 1
7	Joint	Elastomer EPDM	EN 681 - 1
8	Bonnet	Ductile iron EN-GJS-500-7	EN 1563
9	Bolts	Stainless steel A2	EN 10088 - 1

pos.	components	material	standard
10	Bonnet gasket	Elastomer EPDM	EN 681 - 1
11	Wedge	Brass	EN 12164
12	Wedge covering	Elastomer EPDM	EN 681 - 1
13	Body	Ductile iron EN-GJS-500-7	EN 1563
14	Storz hose Couplings	Aluminium AISI 12	EN 1706
15a	Bonnet storz outlet with purgator	Aluminium AISI 12	EN 1706
15b	Bonnet storz inviolable blank cap	Aluminium AISI 12	EN 1706

### Reference and dimensions

code	designation	Inlet D (BSP)	Outlet type	L mm	E mm	H mm	H1 mm	$\varnothing a$ mm	$\varnothing a1$ mm	a2 mm	turns to open	Kg approx.
11209810	Fire plug with storz outlet with purgator	G 1 1/2"	Storz 52	230	25	204	234	13.1	18	35	10	6
11209820	Fire plug with storz inviolable blank cap	G 1 1/2"	Storz 52	137	25	204	234	13.1	18	35	10	6

