

# PORTINHOLAS REDONDA, OVAL OU RETANGULAR

15.100



## Descrição do produto

- Portinholas

## Proteção contra a corrosão

- Pintura preta de base aquosa

## Características

- Fecho sextavado interior de 6 mm
- Opcionalmente poderá ser personalizado
- Disponível noutras cores.



**Fucoli Somepal**  
FUNDAÇÃO DE FERRO, S. A.

Visite o nosso website em [www.fucoli-somepal.pt](http://www.fucoli-somepal.pt)

**Sede:** Estrada de Coselhas, 3000-125 Coimbra – Portugal | Tel.: (+351) 239 490100 | Fax: (+351) 239 490198

**Filial:** Rua de Aveiro 50, 3050-420 Pampilhosa – Portugal | Tel.: (+351) 239 490100 | Fax: (+351) 231 949292 | [comercial@fucoli-somepal.pt](mailto:comercial@fucoli-somepal.pt)

# PORTINHOLAS REDONDA, OVAL OU RETANGULAR

15.100



10603110SA

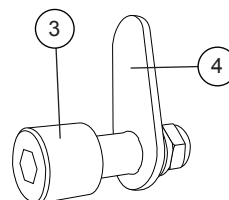
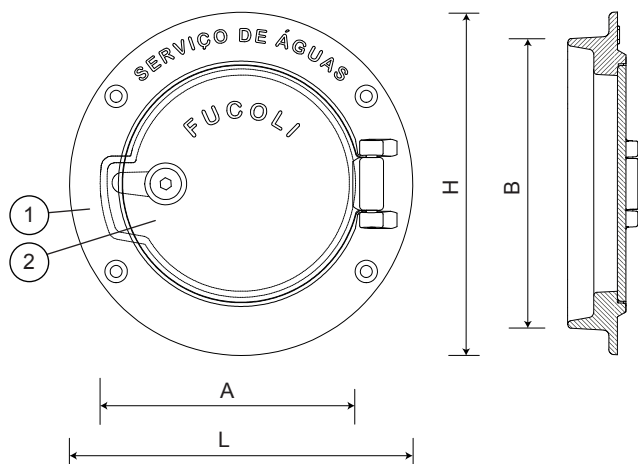

Pormenor do fecho

10609110INC

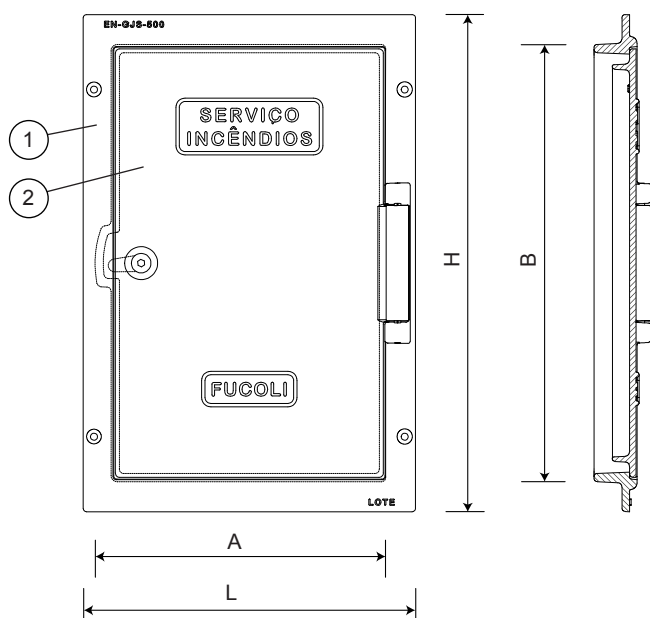

10605010SA

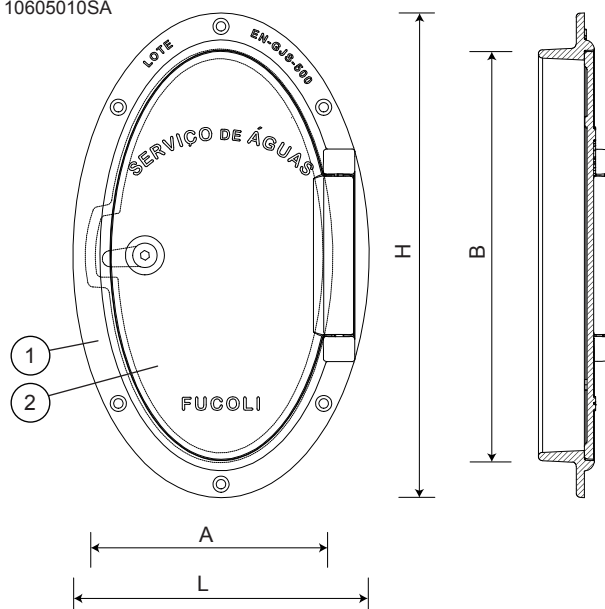

## Lista de componentes

pos.	componentes	material	norma
1	Aro	Ferro fundido dúctil EN-GJS-500-7	EN 1563
2	Tampa	Ferro fundido dúctil EN-GJS-500-7	EN 1563
3	Fecho sextavado	Latão	
4	Trinco	Aço	

## Referências e dimensões

código	modelo	L x H dim. máx	A x B encastramento	abertura útil mm	Kg aprox.
10603110SA	Redonda	∅ 200	153 x 137	∅ 126	2
10605010SA	Oval	220 x 360	182 x 305	150 x 290	4
10609110INC	Retângular	310 x 464	273 x 408	250 x 400	10



**Fucoli Somepal**  
FUNDAÇÃO DE FERRO, S.A.

Visite o nosso website em [www.fucoli-somepal.pt](http://www.fucoli-somepal.pt)

Sede: Estrada de Coselhas, 3000-125 Coimbra – Portugal | Tel.: (+351) 239 490100 | Fax: (+351) 239 490198

Filial: Rua de Aveiro 50, 3050-420 Pampilhosa – Portugal | Tel.: (+351) 239 490100 | Fax: (+351) 231 949292 | [comercial@fucoli-somepal.pt](mailto:comercial@fucoli-somepal.pt)

