

FLANGED SOFT SEALING GATE VALVE S14 NEXUS

with position indicator & open-close limit switch
DN 50 - 300 PN10/16

01.610LS



Product description

- Flanged soft sealing gate valve series NEXUS with open/close indicator and open-close switching for drinking water and neutral liquids
- Service temperature from 0°C (excluding frost) to 70°C

Standards

- Designed according to EN 1074 part 1 & 2 and EN 1171
- Flange drilling to EN 1092-2 PN10/16
- Face-to-face according to EN 558 series 14

Tests

- All valves are individually hydrostatically tested according to EN 1074-1/2 and EN 12266:
- Seal 1.1 x PN (in bar); Body: 1.5 x PN (in bar). Operation torque test

Corrosion protection

- Epoxy powder coating RAL 5005
- Applied internal and external with a minimum coating thickness of 250 µm
- Potable water approved epoxy coating, fusion bonded according to DIN 3476-1, EN 14901-1 and GSK approved

Approvals

- GSK Certificate GSK-ID:1247 (RAL-GZ 662)

Features

- Isolation valve approved for drinking water
- Full bore
- Low operating torque
- Brass stem washer provides stress fixation and low operating torque
- Stainless steel stem with rolled threads produced by cold rolling process, which keeps the steel structure and increase its mechanical resistance
- Stem with stainless steel wedge stop to serve as backstop when the valve is fully open
- Stem sealing with POM bearing with 4 O-rings and a bottom joint in EPDM
- Wedge fully vulcanized with drinking water approved EPDM
- Wedge of polyamide coated guide rails avoiding friction and corrosion
- Wedge with brass nut fixed in the wedge core preventing vibration and ensure a long life span
- Round EPDM bonnet gasket fixed in a recess, surrounding the bolts, ensuring a perfect seal
- Body/bonnet bolts in stainless steel A2 encased and sealed ensuring full corrosion protection
- Open and close indicator for easy viewing of wedge position
- Limit switch by electrical signal transmission with valve opening and closing position information
- Accessories: handwheel [ref. 05.100], stem cap [ref. 05.200]
- On request possibility of stem in stainless steel AISI 316L, NBR sealings and wedge nut in different brass alloys.



RAL GUTZEICHEN
SCHWEISER KENNZEICHEN
VON ARMATUREN UND FORMSTÜCKEN



100% MADE IN EUROPE



Fucoli-Somepal
FUNDIÇÃO DE FERRO, S. A.

Visit our website at www.fucoli-somepal.pt

Head office: Estrada de Coselhas, 3000-125 Coimbra – Portugal | Tel.: (+351) 239 490100

Branch office: Rua de Aveiro 50, 3050-420 Pampilhosa – Portugal | Tel.: (+351) 239 490100 | comercial@fucoli-somepal.pt

FLANGED SOFT SEALING GATE VALVE S14 NEXUS

with position indicator & open-close limit switch
DN 50 - 300 PN10/16

01.610LS

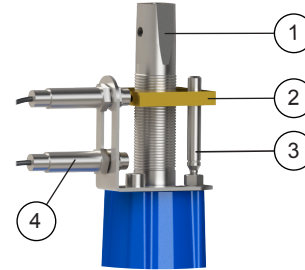
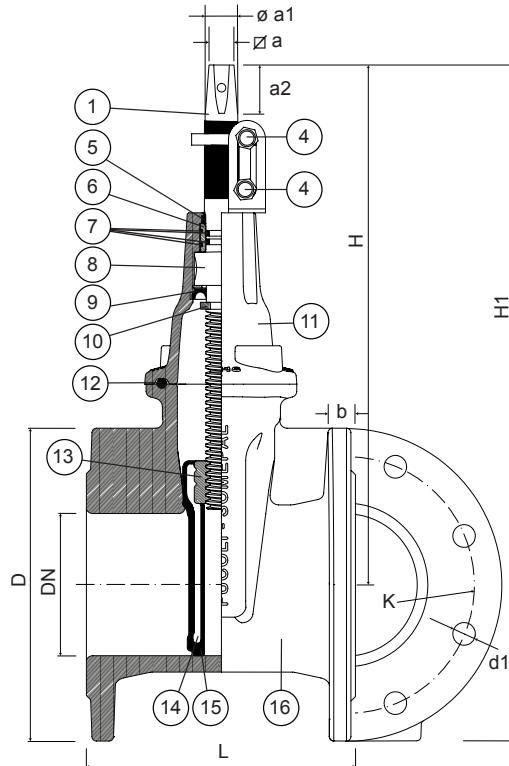

Position indicator & open-close limit switch detail

Component list

pos	components	material	standard
1	Stem	Stainless steel AISI 420	EN 10088-1
2	Position indicator	Brass	EN 12164
3	Indicator guide	Stainless steel AISI 420	EN 10088-1
4	Open-close limit switch	-	-
5	Clearing joint	Elastomer	-
6	Bearing	POM	-
7	O-rings	Elastomer EPDM	EN 681-1
8	Stem washer	Brass DZR CW602N	EN 12164

pos	components	material	standard
9	Joint	Elastomer EPDM	EN 681-1
10	Wedge stop	Stainless steel AISI 420	EN 10088-1
11	Bonnet	Ductile iron EN-GJS-500-7	EN 1563
12	Bonnet gasket	Elastomer EPDM	EN 681-1
13	Wedge nut	Brass DZR CW626N	EN 12164
14	Wedge	Ductile iron EN-GJS-500-7	EN 1563
15	Wedge covering	Elastomer EPDM	EN 681-1
16	Body	Ductile iron EN-GJS-500-7	EN 1563

Reference and dimensions

DN	PN	code	D mm	L mm	H mm	H1 mm	K mm	n° x d1 mm	b mm	a mm	Ø a1 mm	a2 mm	turns to open	Kg aprox.
50	10/16	10729410	165	150	277	360	125	4 x 19	19	14.1	18	29	13	10
60*	10/16	10729415FL	185	170	305	397	135	4 x 19	19	17.1	22	34	14	12
65	10/16	10729415	185	170	305	397	145	4 x 19	19	17.1	22	34	14	12
80	10/16	10729420	200	180	335	435	160	8 x 19	19	17.1	22	34	16	14
100	10/16	10729425	220	190	368	476	180	8 x 19	19	19.1	23	38	20	17
125	10/16	10729430	250	200	407	532	210	8 x 19	19	19.1	23	38	25	22
150	10/16	10729435	285	210	458	600	240	8 x 23	19	19.1	26	38	30	31
200	10	10729440	340	230	531	701	295	8 x 23	20	24.1	28	38	40	47
200	16	10729445	340	230	531	701	295	12 x 23	20	24.1	28	38	40	47
250	10	10729450	400	250	-	-	350	12 x 23	22	27.1	32	47	42	72
250	16	10729455	400	250	-	-	355	12 x 28	22	27.1	32	47	42	72
300	10	10729460	455	270	-	-	400	12 x 23	24.5	27.1	32	47	50	98
300	16	10729465	455	270	-	-	410	12 x 28	24.5	27.1	32	47	50	98

* DN65 valve with DN60 flange drilling



Visit our website at www.fucoli-somepal.pt

Head office: Estrada de Coselhas, 3000-125 Coimbra – Portugal | Tel.: (+351) 239 490100

Branch office: Rua de Aveiro 50, 3050-420 Pampilhosa – Portugal | Tel.: (+351) 239 490100 | comercial@fucoli-somepal.pt

