

SQUARE MANHOLE COVER

SERIES ESTRADA

D400

12.201



Product description

- Square manhole cover series ESTRADA
- Water based black painting
- Hydraulic sealing

Installation location

- Class D400 - Carriageways of roads (including pedestrian streets), hard shoulders and parking areas for all types of road vehicles

Standards

- Performance according to EN 124-1/2

Features

- Ductile cast iron cover and frame (EN-GJS-500-7) with water based black painting
- Cover with non-slip raised pattern according to EN 124-1 designed to allow quick and easy installation
- Fit system to block the cover to the frame designed to avoid noise, even in high traffic intensity
- Cover with two lateral unlocking points and central lifting point for easy operation/handling
- With hydraulic sealing to prevent the odours
- Personalization of the cover with inscriptions and logo in high relief with minimal quantities
- Accessories: key (ref.12.900).



Fucoli Somepal
FUNDAÇÃO DE FERRO, S. A.

Visit our website at www.fucoli-somepal.pt

Head office: Estrada de Coselhas, 3000-125 Coimbra – Portugal | Tel.: (+351) 239 490100 | Fax: (+351) 239 490198

Branch office: Rua de Aveiro 50, 3050-420 Pampilhosa – Portugal | Tel.: (+351) 239 490100 | Fax: (+351) 231 949292 | comercial@fucoli-somepal.pt

SEQUARE MANHOLE COVER SERIES ESTRADA D400

12.201

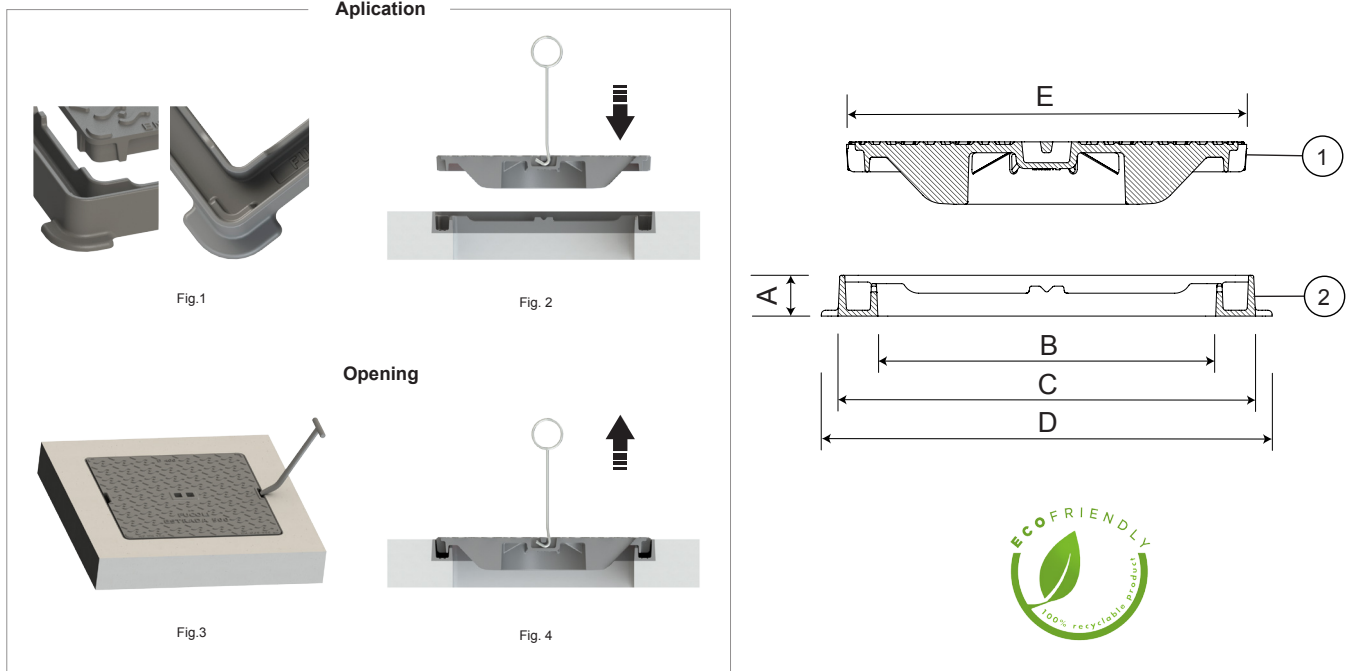

Fig.1 - Anti-noise locking system

Fig.2 - The cover must be seated on the frame so that the four vertices fit together on the frame, remain leveled

Fig.3 - The cover must be unlocked with a suitable operating key (ref. 12.900, cod. 20442018)

Fig.4 - After unlocking, the cover can be lifted with the aid of a key (or hook)

Component list

| pos. | components | material | standard |
|------|------------|---------------------------|----------|
| 1 | Cover | Ductile iron EN-GJS-500-7 | EN 1563 |
| 2 | Frame | Ductile iron EN-GJS-500-7 | EN 1563 |

Reference and dimensions

| Model - DN - Class | code | Frame | | | | Cover | hydraulic sealing Y / N | Weight | |
|--------------------|----------------------|-------------------|-----------------------------|---------------------|------------------------------------|---------------------|----------------------------|------------------------|------------------------|
| | | height mm A | clear opening mm B | external mm C | ext. with stone-bolt mm D | external mm E | | Cover kg approx. | Total kg approx. |
| Estrada 300 - D400 | 24C1BE4RNCBZZZZ00PA | 49 | 206 | 302 | 336 | 281 | Y | 8 | 15 |
| Estrada 400 - D400 | 24C1BO4RNCBZZZZ00PA | 49 | 306 | 402 | 436 | 381 | Y | 18 | 27 |
| Estrada 500 - D400 | 24C1BY4RNCBZZZZ00PA | 49 | 406 | 502 | 542 | 481 | Y | 26 | 39 |
| Estrada 600 - D400 | 24C1CI4RNF BZZZZ00PA | 78 | 506 | 602 | 672 | 581 | Y | 39 | 61 |
| Estrada 700 - D400 | 24C1CS4RNCBZZZZ00PA | 49 | 606 | 702 | 742 | 681 | Y | 51 | 69 |
| Estrada 800 - D400 | 24C1DC4RNDBZZZZ00PA | 51 | 706 | 802 | 842 | 781 | Y | 64 | 85 |



Fucoli Somepal
FUNDIÇÃO DE FERRO, S.A.

Visit our website at www.fucoli-somepal.pt

Head office: Estrada de Coselhas, 3000-125 Coimbra – Portugal | Tel.: (+351) 239 490100 | Fax: (+351) 239 490198

Branch office: Rua de Aveiro 50, 3050-420 Pampilhosa – Portugal | Tel.: (+351) 239 490100 | Fax: (+351) 231 949292 | comercial@fucoli-somepal.pt



100% MADE IN EUROPE