

VALVE OF RESERVOIR BOTTOM

3" - 6"

04.700



Product description

- Valve of reservoir bottom for water and neutral liquids
- Service temperature from 0°C (excluding frost) to 70°C

Corrosion protection

- Epoxy powder coating RAL 5005
- Applied internal and external with a minimum coating thickness of 250 µm
- Potable water approved epoxy coating fusion bonded according EN 14901 and GSK (RAL-GZ662) guidelines

Features

- Valve for drinking water
- Body, cannon and obturator in ductile cast iron EN-GJS-500-7
- For installation in water reservoirs
- Easy and simple installation
- Having an intake cannon with a design and length that allows it to be anchored to the reservoir wall
- Outlet with a recessed outer surface to allow easy installation of a hose.



Fucoli Somepal
FUNDAÇÃO DE FERRO, S. A.

Visit our website at www.fucoli-somepal.pt

Head office: Estrada de Coselhas, 3000-125 Coimbra – Portugal | Tel.: (+351) 239 490100 | Fax: (+351) 239 490198

Branch office: Rua de Aveiro 50, 3050-420 Pampilhosa – Portugal | Tel.: (+351) 239 490100 | Fax: (+351) 231 949292 | comercial@fucoli-somepal.pt

VALVE OF RESERVOIR BOTTOM

3" - 6"

06.700

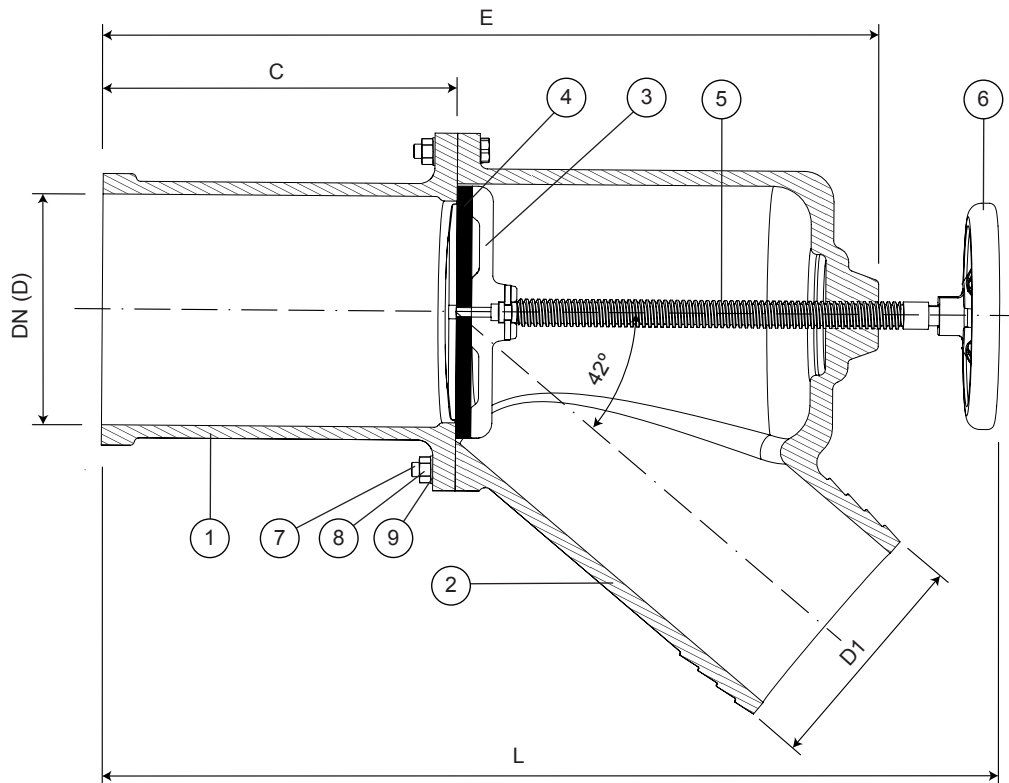

Component list

pos.	components	material	standard
1	Body	Ductile iron EN-GJS-500-7	EN 1563
2	Cannon	Ductile iron EN-GJS-500-7	EN 1563
3	Obturator	Ductile iron EN-GJS-500-7	EN 1563
4	Obturator sealing	Elastomer EPDM	EN 681 - 1
5	Steam	Stainless steel AISI 420	EN 10088 - 1
6	Handwheel	Printed stell ST W24	EN 10111 and 10130
7	Bolts	Steel zinc plated cl 8.8	ISO 898-1
8	Nuts	Steel zinc plated cl 8	ISO 898-2
9	Washers	Steel zinc plated	ISO 898-2

Reference and dimensions

DN (BSP)	(D) mm	code	D1 mm	C mm	E mm	L		Kg approx.
						closed mm A	open mm B	
G 3"	77	10750030	75	200	350	435	510	10
G 50	90	10750035	85	210	380	480	580	14
G 4"	102	10750040	95	210	380	480	575	15
G 65	115	10750045	100	225	435	550	685	18
G 5"	128	10750050	110	210	435	555	690	22
G 6"	153	10750060	130	235	475	580	740	29



Fucoli Somepal
FUNDIÇÃO DE FERRO, S.A.

Visit our website at www.fucoli-somepal.pt

Head office: Estrada de Coselhas, 3000-125 Coimbra – Portugal | Tel.: (+351) 239 490100 | Fax: (+351) 239 490198

Branch office: Rua de Aveiro 50, 3050-420 Pampilhosa – Portugal | Tel.: (+351) 239 490100 | Fax: (+351) 231 949292 | comercial@fucoli-somepal.pt

