

# TRIPLE FUNCTION AIR VALVE

## with isolating valve

### DN 50 - 200 PN10/16

06.300



#### Product description

- Triple function air valve with isolating valve for drinking water, prepared for water supply in firefighting and irrigation systems
- Service temperature from 0°C (excluding frost) to 70°C

#### Standards

- Designed according to EN 1074-4
- Flange drilling to EN 1092-2 PN10/16

#### Tests

All valves are individually hydrostatically tested according to EN 1074-4:

- Seal 1.1 x PN (in bar); Body: 1.5 x PN (in bar)

#### Corrosion protection

- Epoxy powder coating RAL 5005
- Applied internal and external with a minimum coating thickness of 250 µm
- Potable water approved epoxy coating fusion bonded according EN 14901-1 and GSK (RAL-GZ662) guidelines

#### Approvals

- Certificação de potabilidade ACS certificate 25 ACC NY 075

#### Features

- Triple function air valve, designed for the expulsion of the exhaust of large air volume allowing air ingress if pressure loss occurs
- For use in clean water suitable in pipelines up to DN 1200
- With isolating valve for maintenance
- Minimum pressure: 0.3 bar
- The device evacuates great air amounts during the filling of the main
- Allows the inlet of great air amounts (in order to avoid a vacuum effect) during the emptying of the main during normal working conditions
- It must be installed in a vertical position and according to the following parameters:
  - at the highest point;
  - when accentuating the slope in the flow direction;
  - downstream of control valves fitted on descending pipeline;
  - at regular intervals along ascending/descending pipeline, at least every 500 meters;
- On request possibility of float coating, sealing in NBR and stem in stainless steel AISI 316L.



**Fucoli-Somepal**  
FUNDICAO DE FERRO, S.A.

Visit our website at [www.fucoli-somepal.pt](http://www.fucoli-somepal.pt)

Head office: Estrada de Coselhas, 3000-125 Coimbra – Portugal | Tel.: (+351) 239 490100 | Fax: (+351) 239 490198

Branch office: Rua de Aveiro 50, 3050-420 Pampilhosa – Portugal | Tel.: (+351) 239 490100 | Fax: (+351) 231 949292 | [comercial@fucoli-somepal.pt](mailto:comercial@fucoli-somepal.pt)

**TRIPLE FUNCTION AIR VALVE**  
with isolating valve  
**DN 50 - 200 PN10/16**

06.300

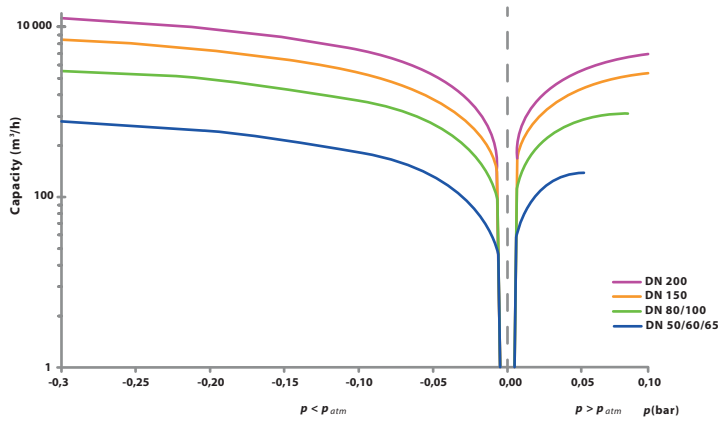
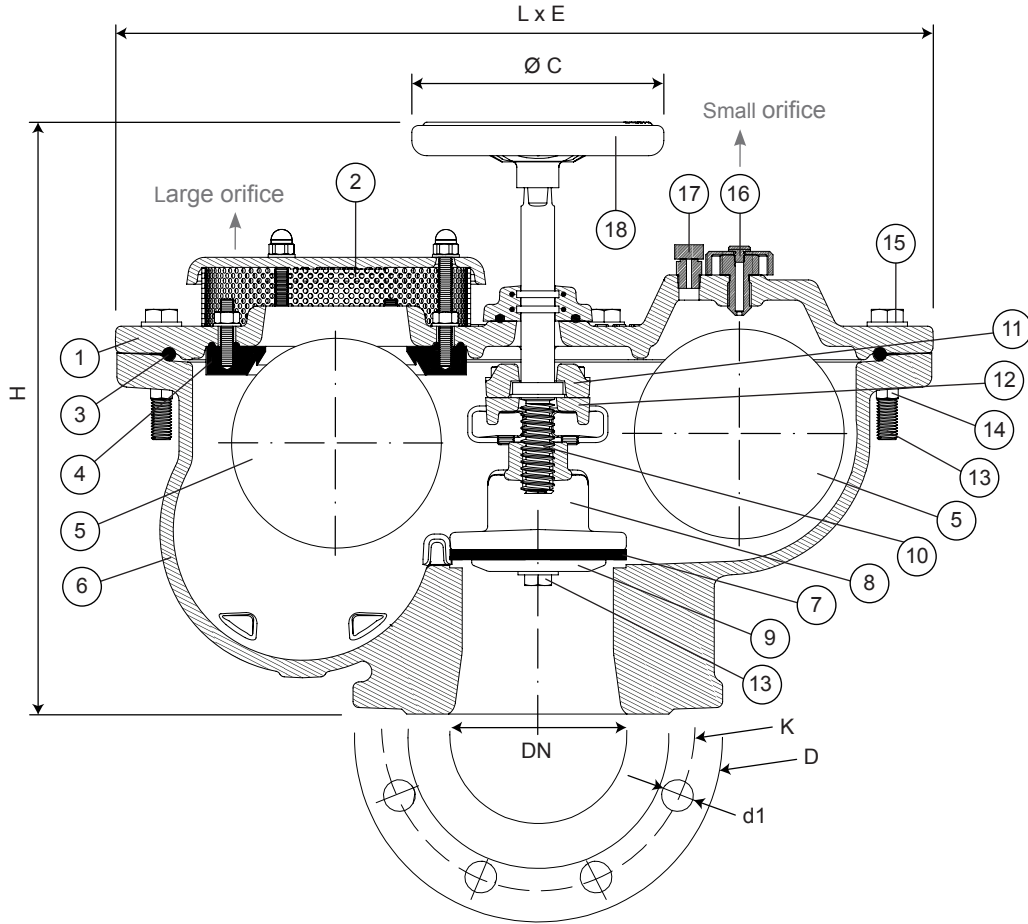

**Component list**

pos.	components	material	standard
1	Bonnet	Ductile iron EN-GJS-500-7	EN 1563
2	Air outlet	Stainless steel AISI 304	EN 10088 - 1
3	O-ring	Elastomer EPDM	EN 681 - 1
4	Air outlet sealing ring	Ductile iron EN-GJS-500-7	EN 1563
	Air outlet sealing ring covering	Elastomer EPDM	EN 681 - 1
5	Flutuator	Steel docol 1000DP	-
	Flutuator covering	Elastomer EPDM	EN 681 - 1
6	Body	Ductile iron EN-GJS-500-7	EN 1563
7	Obturator sealing	Elastomer EPDM	EN 681 - 1
8	Obturator	Ductile iron EN-GJS-500-7	EN 1563
9a	Obturator sealing fixing washer DN50-DN65	Brass CuZn39Pb3	EN 12164

pos.	components	material	standard
9b	Obturator sealing fixing washer DN80-DN200	Ductile iron EN-GJS-500-7	EN 1563
10	Stem	Stainless steel AISI 420	EN 10088 - 1
11	Stem support	Ductile iron EN-GJS-500-7	EN 1563
12	Stem guide	Ductile iron EN-GJS-500-7	EN 1563
13	Bolts	Stainless steel A2	EN 10088 - 1
14	Nuts	Stainless steel A4	EN 10088 - 1
15	Washers	Stainless steel A2	EN 10088 - 1
16	Nozzle	Brass CuZn39Pb3	EN 12164
17	Control purger	Brass CuZn39Pb3	EN 12164
18	Handwheel	Printed stell ST W24	EN 10111 and 10130

continued on next page

**TRIPLE FUNCTION AIR VALVE**  
with isolating valve  
**DN 50 - 200 PN10/16**

06.300



continued from previous page

**Reference and dimensions**

DN	PN	code	D	L	E	H	ø C	K	n° x ø d1	Kg
				mm	mm	mm	mm	mm	mm	approx.
50	10/16	19908010	165	390	200	290	150	125	4 x 19	26
60	10/16	19908015	175	390	200	290	150	135	4 x 19	27
65	10/16	19908020	185	390	200	290	150	145	4 x 19	27
80	10/16	19908030	200	485	245	360	200	160	8 x 19	41
100	10/16	19908040	220	485	245	360	200	180	8 x 19	42
150	10/16	19908050	285	680	360	500	200	240	8 x 23	120
200	10	19908060	340	680	360	500	200	295	8 x 23	122
200	16	19908061	340	680	360	500	200	295	12 x 23	122

DN	Main pipe diameter (DN)	Orifice size	
		Main air outlet	Automatic vacuum outlet
50	65 to 350	1600 mm <sup>2</sup>	12 mm <sup>2</sup>
60			
65			
80	400 to 600	2300 mm <sup>2</sup>	
100			
150	700 to 900	5600 mm <sup>2</sup>	
200	1000 to 1200		



**Fucoli-Somepal**  
FUNDIÇÃO DE FERRO, S. A.

Visit our website at [www.fucoli-somepal.pt](http://www.fucoli-somepal.pt)

Head office: Estrada de Coselhas, 3000-125 Coimbra – Portugal | Tel.: (+351) 239 490100 | Fax: (+351) 239 490198

Branch office: Rua de Aveiro 50, 3050-420 Pampilhosa – Portugal | Tel.: (+351) 239 490100 | Fax: (+351) 231 949292 | [comercial@fucoli-somepal.pt](mailto:comercial@fucoli-somepal.pt)

