

FLANGED SOFT SEALING GATE VALVE S15 3000

DN 40 - 300 PN10/16

16.201



Product description

- Flanged soft sealing gate valve series 3000 with gas sealed
- Service temperature from - 10°C to 60°C

Standards

- Designed according to EN 13774 & EN 1171
- Flange drilling to EN 1092-2 PN10/16
- Face-to-face according to EN 558 series 15

Tests

All valves are individually hydrostatically tested according to EN 13774 and EN 12266:

- Seal 1.1 x PN (in bar); Body: 1.5 x PN (in bar). Operation torque test

Corrosion protection

- Epoxy powder coating RAL 5005
- Applied internal and external with a minimum coating thickness of 250 µm
- Fusion bonded epoxy coating according DIN 3476-1, EN 14901 and GSK approved

Approvals

- KIWA Certificate PED 00044/H
- GSK Epoxy Coating Certificate GSK-ID:1247 (RAL-GZ 662)

Features

- Isolation valve with gas sealed
- Full bore
- Low operating torque
- The valves from DN 250 to DN 300 are equipped with an axial bearing to ensure reduced operating torque
- Stainless steel stem with rolled threads produced by cold rolling process, which keeps the steel structure and increase its mechanical resistance
- Stem sealing system with 4 O-rings in NBR
- O-ring stem sealing exchangeable under pressure
- Wedge fully vulcanized with NBR, gas approved
- Top of the wedge conceived with “soft stop” system, which acts as an end stop for the fully open valve
- Wedge with brass nut fixed in the wedge core preventing vibration and ensure a long life span
- Wedge and body designed with “monorail” system
- Round NBR bonnet gasket fixed in a recess, surrounding the bolts, ensuring a perfect seal
- Body/bonnet bolts in stainless steel A2 encased and sealed ensuring full corrosion protection
- Accessories: handwheel [ref.05.100], stem cap [ref. 05.200], extension spindle [ref. 05.300] and surface box [ref. 05.500].



RAI GUTZEICHEN
SCHWEISSE KENNZEICHEN
VON ARMATUREN UND FORMSTÜCKEN



Fucoli Somepal
FUNDAÇÃO DE FERRO, S. A.

Visit our website at www.fucoli-somepal.pt

Head office: Estrada de Coselhas, 3000-125 Coimbra – Portugal | Tel.: (+351) 239 490100 | Fax: (+351) 239 490198

Branch office: Rua de Aveiro 50, 3050-420 Pampilhosa – Portugal | Tel.: (+351) 239 490100 | Fax: (+351) 231 949292 | comercial@fucoli-somepal.pt

FLANGED SOFT SEALING GATE VALVE S15 3000

DN 40 - 300 PN10/16

16.201

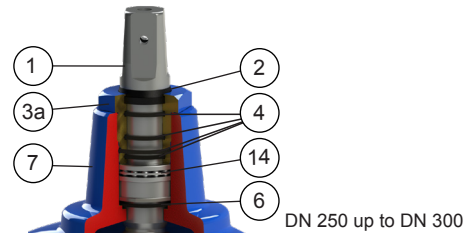
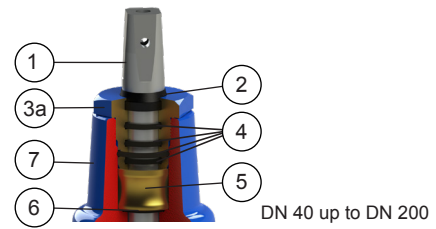
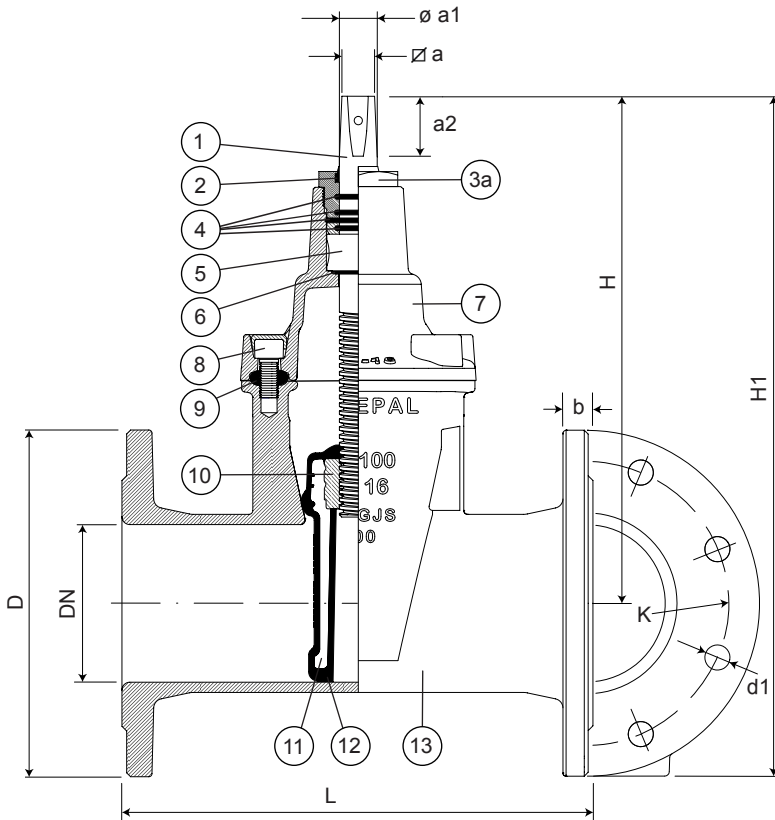

Component list

pos.	components	material	standard
1	Stem	Stainless steel AISI 316L	EN 10088 - 1
2	Clearing joint	Elastomer	-
3a	Gland	Brass	EN 12164
4	O-rings	Elastomer NBR	EN 682
5	Stem washer	Brass	EN 12164
6	O-ring	Elastomer NBR	EN 682
7	Bonnet	Ductile iron EN-GJS-500-7	EN 1563
8	Bolts	Stainless steel A2	EN 10088 - 1

pos.	components	material	standard
9	Bonnet gasket	Elastomer NBR	EN 549
10	Wedge nut	Brass	EN 12164
11	Wedge	Ductile iron EN-GJS-500-7	EN 1563
12	Wedge covering	Elastomer NBR	EN 549
13	Body	Ductile iron EN-GJS-500-7	EN 1563
14	Bearing	Steel	ISO 20516
15	Gland bush	POM	-

Reference and dimensions

DN	PN	code	D	L	H	H1	K	n° x d1	b	$\varnothing a$	$\varnothing a1$	a2	turns to open	Kg approx.
			mm	mm	mm	mm	mm	mm	mm	mm	mm	mm		
40	10/16	10753200	150	240	203	278	110	4 x 19	19	14.1	20	29	10	8
50	10/16	10753205	165	250	235	318	125	4 x 19	19	14.1	20	29	13	11
60	10/16	10753210	175	270	250	338	135	4 x 19	19	17.1	22	34	13	13
65	10/16	10753215	185	270	250	343	145	4 x 19	19	17.1	22	34	13	13
80	10/16	10753220	200	280	290	390	160	8 x 19	19	17.1	22	34	16	17
100	10/16	10753225	220	300	325	435	180	8 x 19	19	19.1	24	38	20	21
125	10/16	10753230	250	325	362	487	210	8 x 19	19	19.1	26	38	25	26
150	10/16	10753235	285	350	425	568	240	8 x 23	19	19.1	28	38	30	38
200	10	10753240	340	400	505	675	295	8 x 23	20	24.1	32	42	34	54
200	16	10753245	340	400	505	675	295	12 x 23	20	24.1	32	42	34	54
250	10	10753250	400	450	595	795	350	12 x 23	22	27.1	36	47	42	80
250	16	10753253	400	450	595	795	355	12 x 28	22	27.1	36	47	42	80
300	10	10753260	455	500	670	898	400	12 x 23	24.5	27.1	36	47	50	132
300	16	10753265	455	500	670	898	410	12 x 28	24.5	27.1	36	47	50	132



Fucoli Somepal
FUNDAÇÃO DE FERRO, S.A.

Visit our website at www.fucoli-somepal.pt

Head office: Estrada de Coselhas, 3000-125 Coimbra – Portugal | Tel.: (+351) 239 490100 | Fax: (+351) 239 490198

Branch office: Rua de Aveiro 50, 3050-420 Pampilhosa – Portugal | Tel.: (+351) 239 490100 | Fax: (+351) 231 949292 | comercial@fucoli-somepal.pt



100% MADE IN EUROPE