

90° BEND INTERNAL THREAD/SOCKET FOR PE

10.6410

Fitting for PE pipe 25 - 63 PN16



Product description

- 90° bend with internal thread and one end with tensile resistant socket joint for PE pipes for drinking water and neutral liquids
- Service temperature from 0°C (excluding frost) to 70°C

Standards

- Socket for PE pipes PE 80 and PE 100 according EN 12201 and DIN 8074
- Internal parallel BSP thread (Type G) according to ISO 228-1 and ISO 1179-1

Corrosion protection

- Epoxy powder coating RAL 5005
- Applied internal and external with a minimum coating thickness of 250 µm
- Potable water approved epoxy coating, fusion bonded according EN 14901 and GSK (RAL-GZ662) guidelines

Features

- Fitting for drinking water
- Body in ductile cast iron (EN-GJS-500-7)
- Sockets with EPDM double lip seal ring and POM tension ring ensuring a perfect sealing and PE pipe restraint
- Fitting to assemble PE pipes to a thread connection
- On request possibility of sealing in NBR.

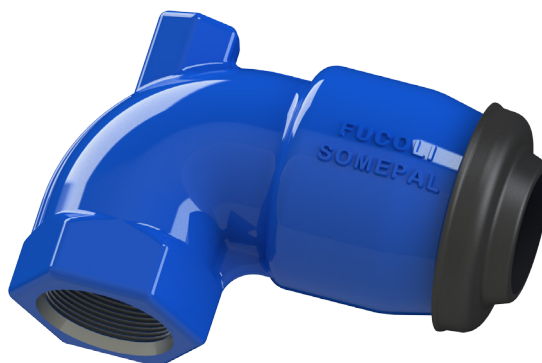

Fucoli Somepal
FUNDAÇÃO DE FERRO, S. A.

Visit our website at www.fucoli-somepal.pt

Head office: Estrada de Coselhas, 3000-125 Coimbra – Portugal | Tel.: (+351) 239 490100 | Fax: (+351) 239 490198

Branch office: Rua de Aveiro 50, 3050-420 Pampilhosa – Portugal | Tel.: (+351) 239 490100 | Fax: (+351) 231 949292 | comercial@fucoli-somepal.pt

90° BEND INTERNAL THREAD/SOCKET FOR PE

Fitting for PE pipe

25 - 63 PN16

10.6410

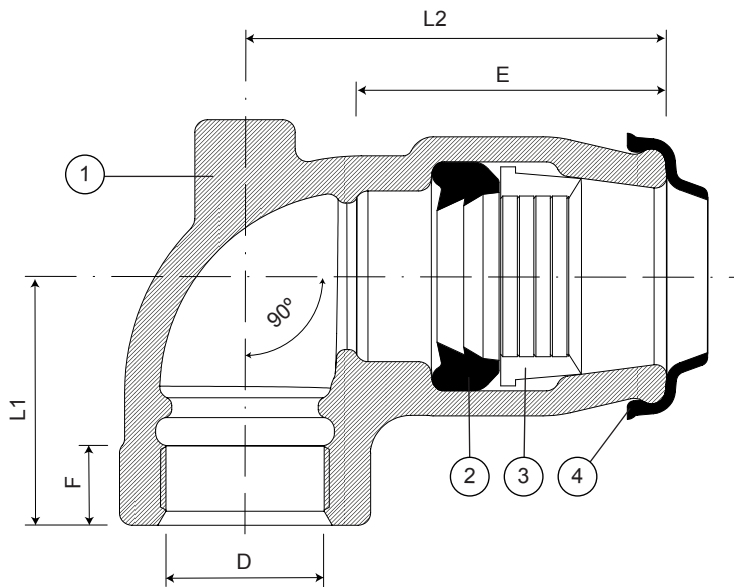

Component list

pos.	components	material	standard
1	Body	Ductile iron EN-GJS-500-7	EN 1563
2	Lip seal ring	Elastomer EPDM	EN 681 - 1
3	Tension ring	POM	EN 10088 - 1
4	Protection cap	Elastomer EPDM	EN 681 - 1

Reference and dimensions

\emptyset ext. PE	D (BSP)	code	L1 mm	L2 mm	E mm	F mm	Kg approx.
25	G 3/4"	10001800	48	77	58	12	1
32	G 1"	10001805	50	91	68	16	2
40	G 1 1/4"	10001810	62	105	77	20	2
50	G 1 1/2"	10001815	65	130	96	20	3
63	G 2"	10001820	80	150	110	25	4



Fucoli Somepal
FUNDAÇÃO DE FERRO, S.A.

Visit our website at www.fucoli-somepal.pt

Head office: Estrada de Coselhas, 3000-125 Coimbra – Portugal | Tel.: (+351) 239 490100 | Fax: (+351) 239 490198

Branch office: Rua de Aveiro 50, 3050-420 Pampilhosa – Portugal | Tel.: (+351) 239 490100 | Fax: (+351) 231 949292 | comercial@fucoli-somepal.pt



100% MADE IN EUROPE