

BUTTERFLY TYPE CHECK VALVE

metal/rubber sealed
DN 150 - 1000 PN10/16

03.200



Product description

- Butterfly type check valve for drinking water and neutral liquids
- Service temperature from 0°C (excluding frost) to 70°C

Standards

- Designed according to EN 1074 part 3
- Flange drilling to EN 1092-2 PN10/16
- Face-to-face according to EN 558 series 14

Tests

All valves are individually hydrostatically tested according to EN 12266:

- Seal 1.1 x PN (in bar); Body: 1.5 x PN (in bar)

Corrosion protection

- Epoxy powder coating RAL 5005
- Applied internal and external with a minimum coating thickness of 250 µm
- Fusion bonded epoxy coating according to DIN 3476-1, EN 14901-1 and GSK (RAL-GZ662) guidelines

Features

- Valve with automatic mechanical closing for installation in pumping systems preventing the return of the flow
- The valve should be installed on the horizontal position, the flow must coincide with the arrow direction engraved on the valve body. For installation in vertical position, consult our technical services
- Valve with double eccentricity of the obturator, allowing shorter closing times, decreased vibration and shocks that occur with reflux
- Body and obturator of the valve in ductile cast iron (EN-GJS-500-7)
- Body and obturator seat supplied as standard in bronze
- Shaft in stainless steel AISI 304
- Adjustable lever and counterweight to help the obturator to close and avoid water hammer, also allows to view the position of the obturator
- On request possibility to be supplied with seat and shaft in stainless steel in AISI 316L.

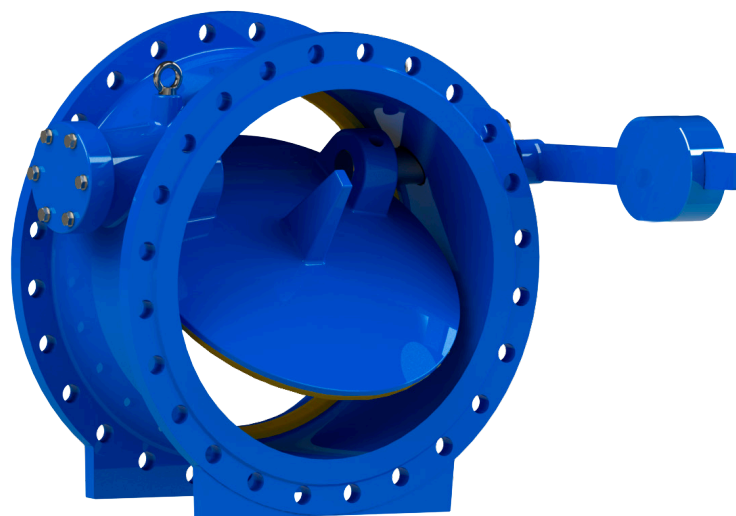

100% MADE IN EUROPE



Fucoli-Somepal
FUNDIÇÃO DE FERRO, S.A.

Visit our website at www.fucoli-somepal.pt

Head office: Estrada de Coselhas, 3000-125 Coimbra – Portugal | Tel.: (+351) 239 490100 | Fax: (+351) 239 490198

Branch office: Rua de Aveiro 50, 3050-420 Pampilhosa – Portugal | Tel.: (+351) 239 490100 | Fax: (+351) 231 949292 | comercial@fucoli-somepal.pt

BUTTERFLY TYPE CHECK VALVE
metal/rubber sealed
DN 150 - 1000 PN10/16

03.200

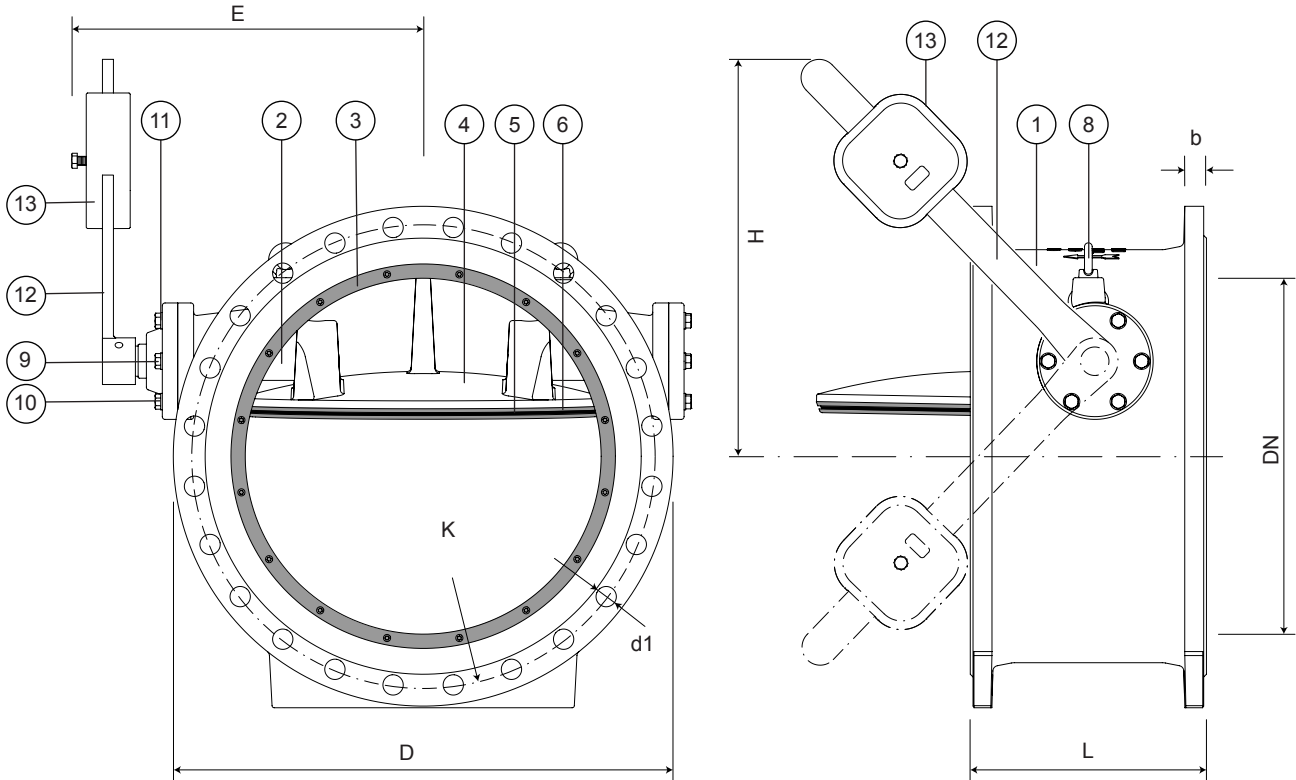

Component list

pos.	components	material	standard
1	Body	Ductile iron EN-GJS-500-7	EN 1563
2	Shaft	Stainless steel AISI 304	EN 10088 - 1
3	Body seat	Bronze CuSn ₇ Zn ₄ Pb ₇	EN 1982
4	Obturator	Ductile iron EN-GJS-500-7	EN 1563
5	Obturator sealing	Elastomer EPDM	EN 681 - 1
6	Bolts	Stainless steel A2	EN 10088 - 1
7	Obturator seat	Bronze CuSn ₇ Zn ₄ Pb ₇	EN 1982
8	Lifting eyes (from DN 200)	Stainless steel A2	EN 10088 - 1
9	Bolts	Steel zinc plated cl 8.8	ISO 898 - 2
10	Nuts	Steel zinc plated cl 8.8	ISO 898 - 2
11	Washers	Steel zinc plated	ISO 898 - 2
12	Lever	Ductile iron EN-GJS-500-7	EN 1563
13	Counterweight	Ductile iron EN-GJS-500-7	EN 1563

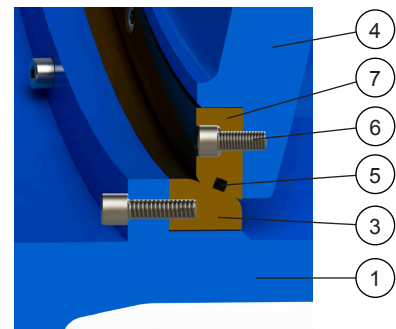

Sealing detail

Reference and dimensions

DN	PN	code	D	L	E	H max.	K	n° x d1	b	Kg approx.
			mm	mm	mm	mm	mm	mm	mm	
150	10/16	10763027	285	210	235	205	240	8 x 23	19	36
200	10	10763028	340	230	275	235	295	8 x 23	20	52
200	16	10763058	340	230	275	235	295	12 x 23	20	52
250	10	10763029	400	250	265	300	350	12 x 23	22	69
250	16	10763059	400	250	265	300	355	12 x 28	22	69
300	10	10763030	455	270	345	310	400	12 x 23	24.5	100
300	16	10763060	455	270	345	310	410	12 x 28	24.5	100
350	10	10763031	505	290	380	385	460	16 x 23	24.5	138
350	16	10763061	520	290	380	385	470	16 x 28	26.5	147
400	10	10763032	565	310	440	450	515	16 x 28	24.5	178
400	16	10763062	580	310	440	450	525	16 x 31	28	188

continued on next page

BUTTERFLY TYPE CHECK VALVE
metal/rubber sealed
DN 150 - 1000 PN10/16

03.200



continued from previous page

DN	PN	code	D	L	E	H	K	n° x d1	b	Kg
			mm	mm	mm	max. mm	mm	mm	mm	approx.
450	10	10763033	615	330	440	475	565	20 x 28	25.5	214
450	16	10763063	640	330	440	475	585	20 x 31	30	234
500	10	10763035	670	350	500	500	620	20 x 28	26.5	268
500	16	10763064	715	350	500	500	650	20 x 34	31.5	302
600	10	1 0763036	780	390	530	597	725	20 x 31	30	354
600	16	10763065	840	390	530	597	770	20 x 37	36	384
700	10	10763037	895	430	615	655	840	24 x 31	32.5	530
700	16	10763066	910	430	615	655	840	24 x 37	39.5	569
800	10	10763038	1015	470	680	760	950	24 x 34	35	725
800	16	10763067	1025	470	680	760	950	24 x 41	43	769
900	10	10763039	1115	510	780	850	1050	28 x 34	37.5	920
900	16	10763068	1125	510	780	850	1050	28 x 41	46.5	937
1000	10	10763040	1230	550	820	945	1160	28 x 37	40	1124
1000	16	10763070	1255	550	820	945	1170	28 x 44	50	1210



Fucoli-Somepal
FUNDIÇÃO DE FERRO, S.A.

Visit our website at www.fucoli-somepal.pt

Head office: Estrada de Coselhas, 3000-125 Coimbra – Portugal | Tel.: (+351) 239 490100 | Fax: (+351) 239 490198

Branch office: Rua de Aveiro 50, 3050-420 Pampilhosa – Portugal | Tel.: (+351) 239 490100 | Fax: (+351) 231 949292 | comercial@fucoli-somepal.pt

