

END CAP SOCKET PE/UPVC BLOCKPLUS

for PE and uPVC pipes

63 - 200 PN16

10.2300



Product description

- End cap socket with BLOCKPLUS restrain system for PE and uPVC pipes for drinking water and neutral liquids
- Service temperature from 0°C (excluding frost) to 70°C

Standards

- For PE pipes PE 80 and PE 100 according EN 12201 and DIN 8074
- For uPVC pipes according EN ISO 1452-2

Corrosion protection

- Epoxy powder coating RAL 3011
- Applied internal and external with a minimum coating thickness of 250 µm
- Potable water approved epoxy coating fusion bonded according EN 14901-1 and GSK (RAL-GZ662) guidelines

Approvals

- ACS Potability Certificate 25 ACC NY 274

Features

- Fittings for drinking water
- Ductile iron cast iron EN-GJS-500-7 body and ring
- Socket ends with drinking water approved EPDM double lip seal ring to ensure a perfect sealing
- Innovative restraint system design, each socket it features a top-facing bolt design, enabling quick and easy installation suitable for PE and uPVC pipes, preventing axial pipe pull out
- The grip ring acts independently of the pipe lip seal ring gasket and is ensured by tightening the lock ring system
- The locking ring is adjustable before tightening, allowing easy installation - a new conception of design
- Blockplus range: soft sealing gate valve (ref. 01.410), flange adaptor (ref. 09.210), double socket 90° (ref. 10.2000), double socket 45° (ref. 10.2001), socket collar (ref. 10.2100), all socket tee (ref. 10.2200) e end cap socket (ref. 10.2300).

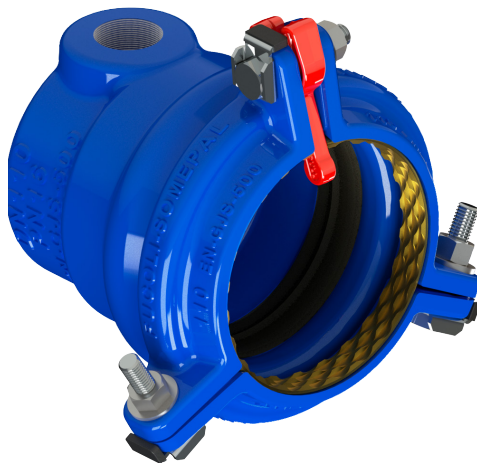

Fucoli-Somepal
FUNDAÇÃO DE FERRO, S.A.

Visit our website at www.fucoli-somepal.pt

Head office: Estrada de Coselhas, 3000-125 Coimbra – Portugal | Tel.: (+351) 239 490100 | Fax: (+351) 239 490198

Branch office: Rua de Aveiro 50, 3050-420 Pampilhosa – Portugal | Tel.: (+351) 239 490100 | Fax: (+351) 231 949292 | comercial@fucoli-somepal.pt

END CAP SOCKET PE/UPVC BLOCKPLUS

for PE and uPVC pipes

63 - 200 PN16

10.2300

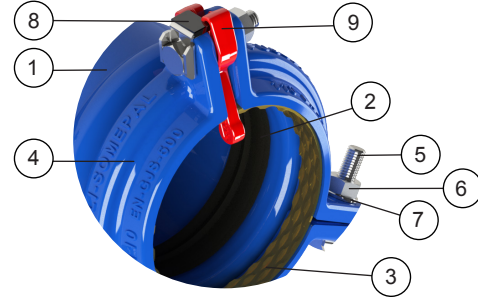
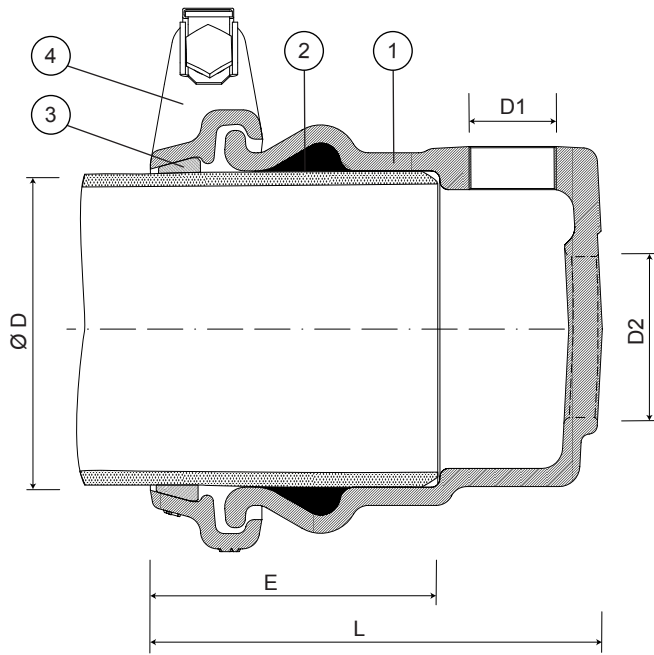

Lock ring BLOCKPLUS

Component list

pos.	components	material	standard
1	Body	Ductile iron EN-GJS-500-7	EN 1563
2	Lip seal ring	Elastomer EPDM	EN 681-1
3	Grip ring	Brass	EN 1982
4	Lock ring	Ductile iron EN-GJS-500-7	EN 1563
5	Bolts	Stainless stell A2	EN 10088-1

pos.	components	material	standard
6	Nuts	Stainless steel A4	EN 10088-1
7	Washer	Stainless stell A2	EN 10088-1
8	Bolt head locking device	Stainless stell A2 with protection coating	EN 10088-1
9	Stop tab	Polypropylene	

Reference and dimensions

Ø D ext. PE/PVC	code		L mm	E mm	Kg approx.
	radial 1" D1	axial 2" D2			
63	10132400	-	144	86	3
75	10132405	10132505	152	94	4
90	10132410	10132510	155	97	6
110	10132415	10132515	160	102	5
125	10132420	10132520	163	108	6
160	10132425	10132525	172	125	8
200	10132430	10132530	182	138	10



Fucoli-Somepal
FUNDAÇÃO DE FERRO, S. R. L.

Visit our website at www.fucoli-somepal.pt

Head office: Estrada de Coselhas, 3000-125 Coimbra – Portugal | Tel.: (+351) 239 490100 | Fax: (+351) 239 490198

Branch office: Rua de Aveiro 50, 3050-420 Pampilhosa – Portugal | Tel.: (+351) 239 490100 | Fax: (+351) 231 949292 | comercial@fucoli-somepal.pt

