

# MULTIMATERIALS COUPLING WITH GFIX® GRIP SYSTEM and gas sealed DN 50 - 400 PN5

16.400



## Product description

- Multimaterial coupling with GFIX® grip system and gas sealed
- Service temperature from - 15°C to 50°C
- Working pressure: 5 bar

## Standards

- Designed according to EN 969

## Test according

- EN 969: Positive internal pressure

## Corrosion protection

- Epoxy powder coating RAL 5005
- Applied internal and external with a minimum coating thickness of 250 µm
- Fusion bonded epoxy coating according EN 14901 and GSK approved

## Approvals

- GSK Epoxy Coating Certificate GSK-ID:1247 (RAL-GZ 662)

## Features

- Multimaterials coupling with gas sealed
- GFIX® system allows a high-fidelity seal/locking of the assembly without pipe disconnections
- The pipe block is performed by a tempered serrated rivets system mounted on the conical claws that fit and grip causing no damage on the pipe
- Sealing system in NBR, gas approved
- The sealing is carried out through a seal with O-rings, mounted on a ring made by the grip support, which will slide until being pressed against the pipe
- Allows a maximum angle deflection of 8°
- Bolts and washers in stainless steel A2 and nuts in stainless steel A4 with anti-friction coated protection
- Bolts ends protected with plastic caps
- Allow the connection between pipes with several external diameters and different materials (PE, uPVC, ductile iron, steel, abestos ciment, glass fiber pipes and others)
- For PE or uPVC pipe applications, should be used an insert in stainless steel (ref.15.400)
- On request possibility of bolts, washers and nuts in stainless steel A4.



**Fucoli Somepal**  
FUNDAÇÃO DE FERRO, S. A.

Visit our website at [www.fucoli-somepal.pt](http://www.fucoli-somepal.pt)

**Head office:** Estrada de Coselhas, 3000-125 Coimbra – Portugal | Tel.: (+351) 239 490100 | Fax: (+351) 239 490198

**Branch office:** Rua de Aveiro 50, 3050-420 Pampilhosa – Portugal | Tel.: (+351) 239 490100 | Fax: (+351) 231 949292 | [comercial@fucoli-somepal.pt](mailto:comercial@fucoli-somepal.pt)

# MULTIMATERIALS COUPLING WITH GFIX® GRIP SYSTEM and gas sealed DN 50 - 400 PN5

16.400

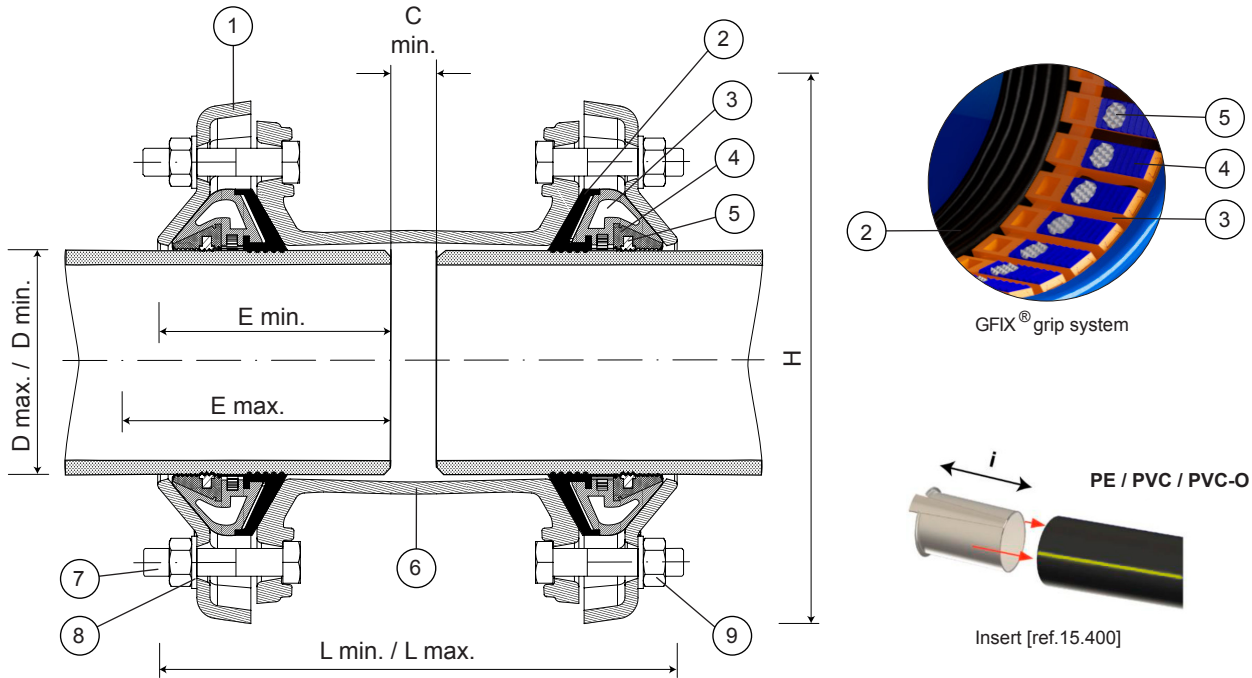

## Component list

pos.	components	material	standard
1	Locking ring	Ductile iron EN-GJS-500-7	EN 1563
2	Sealing	Elastomer NBR	EN 682
3	Gripper support	POM	-
4	Gripper	POM	-
5	Rivets with milling	Tempered steel cq 15	DIN 1654

pos.	components	material	standard
6	Body	Ductile iron EN-GJS-500-7	EN 1563
7	Bolts	Stainless steel A2	EN 10088 - 1
8	Washers	Stainless steel A2	EN 10088 - 1
9	Nuts	Stainless steel A4	EN 10088 - 1

## Reference and dimensions

DN	D	code	L	H	E	C	Kg approx.	i	insert* mm	Bolt	Torque
mm	min./max. mm - mm		min./max. mm - mm	mm	min./max. mm - mm	min. mm					
50	39 - 52	10900800	233 - 250	162	90 - 115	20	6	175	6 x M12	19 mm	50 - 70 Nm
50	49 - 64	10900802	231 - 250	175	90 - 115	20	6	175	6 x M12	19 mm	50 - 70 Nm
65	63 - 83	10900804	258 - 286	209	105 - 133	20	12	175	8 x M12	19 mm	50 - 70 Nm
80	72 - 93	10900805	257 - 286	217	105 - 133	20	13	175	8 x M12	19 mm	50 - 70 Nm
80	78 - 103	10900806	250 - 286	229	105 - 133	20	14	175	8 x M12	19 mm	50 - 70 Nm
100	87 - 117	10900808	244 - 286	243	105 - 133	20	15	175	8 x M12	19 mm	50 - 70 Nm
100	100 - 130	10900810	253 - 299	256	105 - 140	20	16	175	8 x M16	24 mm	90 - 120 Nm
125	117 - 147	10900812	253 - 299	273	105 - 140	20	19	175	8 x M16	24 mm	90 - 120 Nm
150	138 - 168	10900814	253 - 299	294	105 - 140	20	21	175	8 x M16	24 mm	90 - 120 Nm
150	152 - 182	10900816	288 - 330	308	115 - 155	20	21	200	8 x M16	24 mm	90 - 120 Nm
175	172 - 202	10900818	288 - 330	325	115 - 155	20	23	200	8 x M16	24 mm	90 - 120 Nm
200	198 - 228	10900820	288 - 330	354	115 - 155	20	28	200	8 x M16	24 mm	90 - 120 Nm
225	217 - 257	10900822	300 - 359	392	130 - 170	20	32	225	12 x M16	24 mm	90 - 120 Nm
250	245 - 285	10900824	383 - 440	434	150 - 210	20	39	225	12 x M16	24 mm	90 - 120 Nm
300	300 - 340	10900826	383 - 440	479	150 - 210	20	51	225	16 x M16	24 mm	90 - 120 Nm
350	340 - 380	10900828	383 - 440	519	150 - 210	20	55	225	16 x M16	24 mm	90 - 120 Nm
400	390 - 430	10900830	383 - 440	571	150 - 210	20	70	225	16 x M16	24 mm	90 - 120 Nm

\* recommended for PE, uPVC or PVC-O pipes - insert [ref. 15.400]

Table of tolerances and pipes on next page



## TABLE OF TOLERANCES AND PIPES

Tolerances	code	Pipes									
		HDPE / PE / PVC / PVC-u	Ductile iron		Steel	Asbestos cement					
D min. - max. mm - mm		ø ext. pipe mm	DN	ø ext. pipe mm	ø ext. pipe mm	DN	Class 6	Class 12	Class 18	Class 24	Class 30
39 - 52	10900800	40 50	-	-	42.4 48.3	-	-	-	-	-	-
49 - 64	10900802	50 63	40	56	48.3 60.3	-	-	-	-	-	-
63 - 83	10900804	63 75	50 60 65	66 77 82	76.1	50 60	66 76	66 76	66 76	66 76	66 78
72 - 93	10900805	75 90	60 65	77 82	76.1 88.9	60	76	76	76	76	76
78 - 103	10900806	90	65 80	82 98	88.9 101.6	60 80	- 96	- 96	- 96	- 96	78 -
87 - 117	10900808	90 110	80	98	88.9 101.6 114.3	80 100	96 116	96 116	96 -	98 -	104 -
100 - 130	10900810	110 125	100	118	101.6 114.3	80 100	- 116	- 116	- 118	- 122	104 128
117 - 147	10900812	125 140	100 125	118 144	139.7	100 125	- 141	- 141	118 145	122 -	128 -
138 - 168	10900814	140 160	125	144	139.7	125 150	141 168	141 168	145 -	151 -	157 -
152 - 182	10900816	160 180	150	170	168.3 177.8	125 150	- 168	- 168	- 174	- 180	157 -
172 - 202	10900818	180 200	-	-	177.8 193.7	150	-	-	174	180	188
198 - 228	10900820	200 225	200	222	219.1	200	220	222	228	-	-
217 - 257	10900822	225 250	200	222	244.5	200	220	222	228	238	250
245 - 285	10900824	250 280	250	274	273	200 250	- 272	- 276	- -	- -	250 -
300 - 340	10900826	315	300	326	323.9	300	324	330	338	-	-
340 - 380	10900828	355	350	378	355.6	300 350	- 376	- -	- -	352 -	366 -
390 - 430	10900830	400	400	429	406.4	350 400	- 428	- -	- -	- -	426 -

