

# FLANGED SOFT SEALING GATE VALVE S15 NEXUS

with open/close indicator  
DN 50 - 300 PN10/16

01.611



## Product description

- Flanged soft sealing gate valve series NEXUS with open/close indicator for drinking water and neutral liquids
- Service temperature from 0°C (excluding frost) to 70°C

## Standards

- Designed according to EN 1074 part 1 & 2 and EN 1171
- Flange drilling to EN 1092-2 PN10/16
- Face-to-face according to EN 558 series 15

## Tests

All valves are individually hydrostatically tested according to EN 1074-1/2 and EN 12266:

- Seal 1.1 x PN (in bar); Body: 1.5 x PN (in bar). Operation torque test

## Corrosion protection

- Epoxy powder coating RAL 5005
- Applied internal and external with a minimum coating thickness of 250 µm
- Potable water approved epoxy coating, fusion bonded according to DIN 3476-1, EN 14901 and GSK approved

## Approvals

- GSK Certificate GSK-ID:1247 (RAL-GZ 662)

## Features

- Isolation valve approved for drinking water
- Full bore
- Low operating torque
- Brass stem washer provides stress fixation and low operating torque
- Stainless steel stem with rolled threads produced by cold rolling process, which keeps the steel structure and increase its mechanical resistance
- Stem with stainless steel wedge stop to serve as backstop when the valve is fully open
- Stem sealing with POM bearing with 4 O-rings and a bottom joint in EPDM
- Wedge fully vulcanized with drinking water approved EPDM
- Wedge of polyamide coated guide rails avoiding friction and corrosion
- Wedge with brass nut fixed in the wedge core preventing vibration and ensure a long life span
- Round EPDM bonnet gasket fixed in a recess, surrounding the bolts, ensuring a perfect seal
- Body/bonnet bolts in stainless steel A2 encased and sealed ensuring full corrosion protection
- Position indicator for visual display of gate position
- On request possibility of stem in stainless steel AISI 316L and NBR sealings.



RAL GUTZEICHEN  
SCHWEISZ KENNZEICHEN  
VON ARMATUREN UND FORMSTÜCKEN



**Fucoli Somepal**  
FUNDAÇÃO DE FERRO, S. A.

Visit our website at [www.fucoli-somepal.pt](http://www.fucoli-somepal.pt)

Head office: Estrada de Coselhas, 3000-125 Coimbra – Portugal | Tel.: (+351) 239 490100 | Fax: (+351) 239 490198

Branch office: Rua de Aveiro 50, 3050-420 Pampilhosa – Portugal | Tel.: (+351) 239 490100 | Fax: (+351) 231 949292 | [comercial@fucoli-somepal.pt](mailto:comercial@fucoli-somepal.pt)

# FLANGED SOFT SEALING GATE VALVE S15 NEXUS

with open/close indicator  
DN 50 - 300 PN10/16

01.611

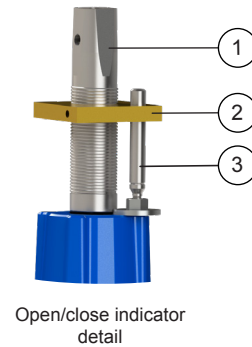
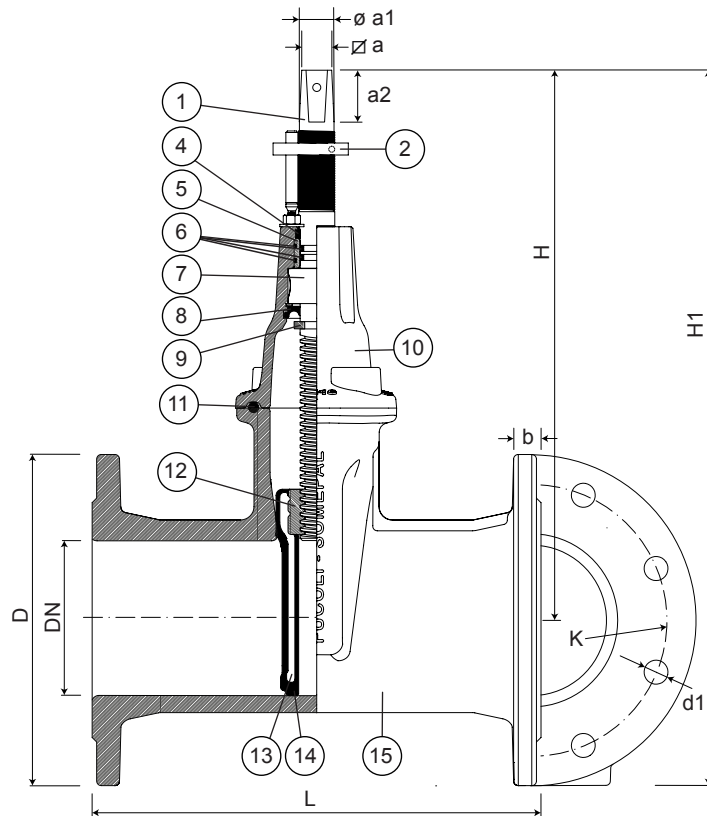

## Component list

pos.	components	material	standard
1	Stem	Stainless steel AISI 420	EN 10088 - 1
2	Open-close indicated	Brass	EN 12164
3	Indicator guide	Stainless steel AISI 420	EN 10088 - 1
4	Clearing joint	Elastomer	
5	Bearing	POM	
6	O-rings	Elastomer EPDM	EN 681 -1
7	Stem washer	Brass	EN 12164
8	Joint	Elastomer EPDM	EN 681 -1
9	Wedge stop	Stainless steel AISI 420	EN 10088 - 1

pos.	components	material	standard
10	Bonnet	Ductile iron EN-GJS-500-7	EN 1563
11	Bonnet gasket	Elastomer EPDM	EN 681 -1
12	Wedge nut	Brass	EN 12164
13	Wedge	Ductile iron EN-GJS-500-7	EN 1563
14	Wedge covering	Elastomer EPDM	EN 681 -1
15	Body	Ductile iron EN-GJS-500-7	EN 1563

## Reference and dimensions

DN	PN	code	D	L	H	H1	K	n° x d1	b	$\varnothing a$	$\varnothing a1$	a2	turns to open	Kg approx.
			mm	mm	mm	mm	mm	mm	mm	mm	mm	mm		
50	10/16	10732210	165	250	277	360	125	4 x 19	19	14.1	18	29	13	10
65	10/16	10732215	185	270	305	397	145	4 x 19	19	17.1	22	34	14	12
80	10/16	10732220	200	280	335	435	160	8 x 19	19	17.1	22	34	16	14
100	10/16	10732225	220	300	368	476	180	8 x 19	19	19.1	23	38	20	19
125	10/16	10732230	250	325	407	532	210	8 x 19	19	19.1	23	38	25	22
150	10/16	10732235	285	350	458	600	240	8 x 23	19	19.1	26	38	30	35
200	10	10732240	340	400	531	701	295	8 x 23	20	24.1	28	38	40	52
200	16	10732245	340	400	531	701	295	12 x 23	20	24.1	28	38	40	52
250*	10	10732250	400	450	-	-	350	12 x 23	22	-	-	-	-	-
250*	16	10732255	400	450	-	-	355	12 x 28	22	-	-	-	-	-
300*	10	10732260	455	500	-	-	400	12 x 23	24.5	-	-	-	-	-
300*	16	10732265	455	500	-	-	410	12 x 28	24.5	-	-	-	-	-

\* On request



**Fucoli Somepal**  
FUNDIÇÃO DE FERRO, S.A.

Visit our website at [www.fucoli-somepal.pt](http://www.fucoli-somepal.pt)

Head office: Estrada de Coselhas, 3000-125 Coimbra – Portugal | Tel.: (+351) 239 490100 | Fax: (+351) 239 490198

Branch office: Rua de Aveiro 50, 3050-420 Pampilhosa – Portugal | Tel.: (+351) 239 490100 | Fax: (+351) 231 949292 | [comercial@fucoli-somepal.pt](mailto:comercial@fucoli-somepal.pt)



100% MADE IN EUROPE