

BLIND FLANGE DN 40 - 1000 PN10/16

11.2800



Product description

- Blind flange for waste water
- Service temperature from 0°C (excluding frost) to 70°C

Standards

- Designed according to EN 598
- Flange drilling to EN 1092-2 (ISO 7005-2) PN 10/16

Corrosion protection

- Epoxy powder coating RAL 3011
- Applied internal and external with a minimum coating thickness of 250 µm
- Fusion bonded epoxy coating according EN 14901 and GSK (RAL-GZ662) guidelines

Features

- Blind flange for waste water
- Body in ductile cast iron (EN-GJS-500-7)
- Simple and fast instalation
- The flanged fittings for sewerage applications from Fucoli-Somepal have CE mark in accordance with standard EN 598 annex ZA
- Accessories: kit flange in steel zinc plated [ref. 15.500] or kit flange in stainless steel [ref. 15.510].

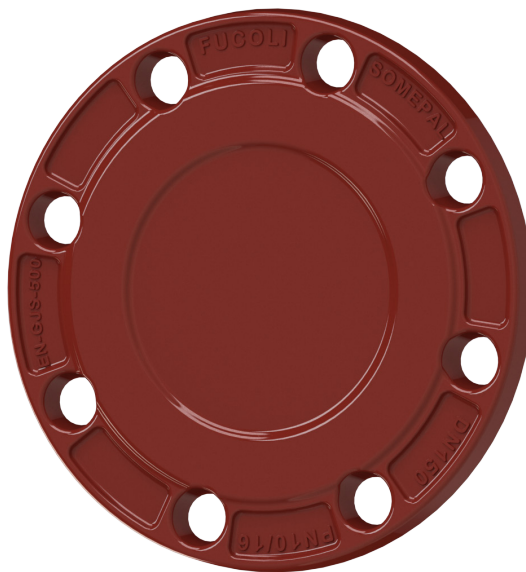

Fucoli Somepal
FUNDAÇÃO DE FERRO, S. A.

Visit our website at www.fucoli-somepal.pt

Head office: Estrada de Coselhas, 3000-125 Coimbra – Portugal | Tel.: (+351) 239 490100 | Fax: (+351) 239 490198

Branch office: Rua de Aveiro 50, 3050-420 Pampilhosa – Portugal | Tel.: (+351) 239 490100 | Fax: (+351) 231 949292 | comercial@fucoli-somepal.pt

BLIND FLANGE

DN 40 - 1000 PN10/16

11.2800

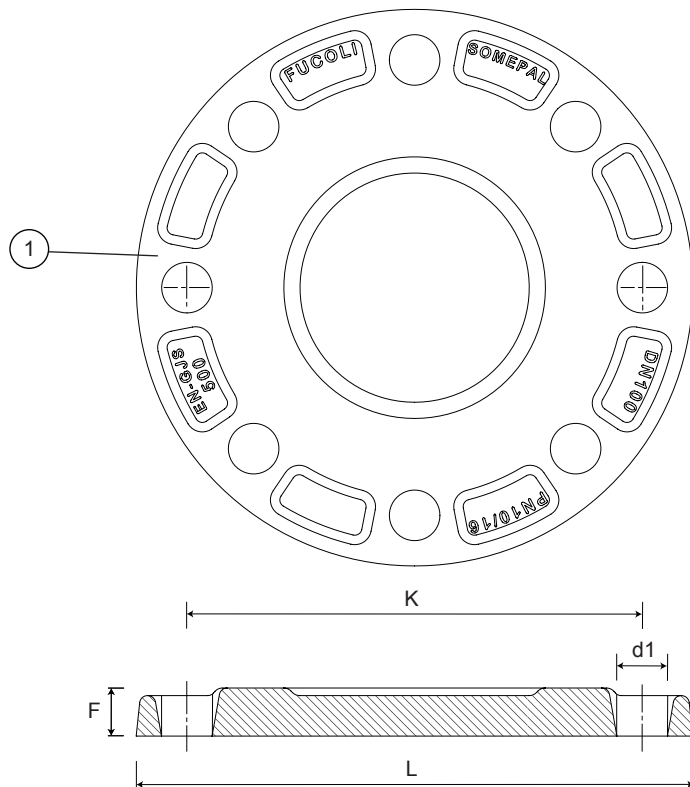

Component list

pos.	components	material	standard
1	Flange	Ductile iron EN-GJS-500-7	EN 1563

Reference and dimensions

DN	PN	code	L mm	F mm	K mm	n° x d1 mm	Kg approx.
40	10/16	10125000	150	19	110	4 x 19	3
50	10/16	10125050	165	19	125	4 x 19	3
60/65	10/16	10125100	175/185	19	135/145	4 x 19	4
80	10/16	10125150	200	19	160	8 x 19	4
100	10/16	10125200	220	19	180	8 x 19	5
125	10/16	10125250	250	19	210	8 x 19	6
150	10/16	10125300	285	19	240	8 x 23	7
200	10/16	10125351	340	20	295	8-12 x 23	11
250	10/16	10125401	400	22	350/355	12 x 23/28	16
300	10/16	10125451	455	24.5	400/410	12 x 23/28	23
350	10	10125500	505	24.5	460	16 x 23	33
350	16	10125502	520	26.5	470	16 x 28	34
400	10	10125550	565	24.5	515	16 x 28	38
400	16	10125552	580	28	525	16 x 31	40
450	10	10125600	615	25.5	565	20 x 28	46
450	16	10125602	640	30	585	20 x 31	48
500	10	10125650	670	26.5	620	20 x 28	81
500	16	10125652	715	31.5	650	20 x 34	-
600	10	10125700	780	30	725	20 x 31	90
600	16	10125702	840	36	770	20 x 37	100
700	10	10125750	895	32.5	840	24 x 31	132
700	16	10125752	910	39.5	840	24 x 37	150

continued on next page

BLIND FLANGE

DN 40 - 1000 PN10/16/25

11.2800



continued from previous page

DN	PN	code	L mm	F mm	K mm	n° x d1 mm	Kg approx.
800	10	10125800	1015	35	950	24 x 34	191
800	16	10125802	1025	43	950	24 x 41	195
900	10	10125850	1115	37.5	1050	28 x 34	220
900	16	10125852	1125	46.5	1050	28 x 41	-
1000	10	10125900	1230	40	1160	28 x 37	290
1000	16	10125902	1255	50	1170	28 x 44	400



Fucoli Somepal
FUNDAÇÃO DE FERRO, S.A.

Visit our website at www.fucoli-somepal.pt

Head office: Estrada de Coselhas, 3000-125 Coimbra – Portugal | Tel.: (+351) 239 490100 | Fax: (+351) 239 490198

Branch office: Rua de Aveiro 50, 3050-420 Pampilhosa – Portugal | Tel.: (+351) 239 490100 | Fax: (+351) 231 949292 | comercial@fucoli-somepal.pt



100% MADE IN EUROPE